

CAUTION:

DO NOT STAND ON OR CLIMB ON THE SYSTEM. DO NOT DROP HEAVY ITEMS ON THE SYSTEM SHELVES. PLACE HEAVIER ITEMS ON THE LOWER SHELVES AND LIGHTER ONES ON TOP. DO NOT MOVE THE SYSTEM WHILE LOADED.

WARNING:

HOLDS 500 LBS (226.8 KG) TOTAL ON WHEELS.

HOLDS 600 LBS (272.2 KG) PER SHELF ON LEVELING FEET.

HOLDS 3,000 LBS (1360.8 KG) TOTAL ON LEVELING FEET.

If you are missing any parts, have any questions, or need additional assistance in assembly, please contact our customer service department.

READ & SAVE THESE INSTRUCTIONS ©2015 Seville Classics, Inc.

5-SHELF COMMERCIAL SHELVING

Model No. 18240ZB

ASSEMBLY INSTRUCTIONS

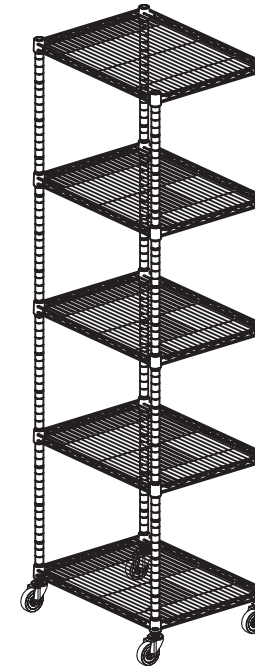

Customer Service

Tel 1.310.533.3800

Tel 1.800.323.5565

Fax 1.310.533.3899

Monday - Friday 8:30 am - 4:30 pm PST



Seville Classics, Inc.

Torrance, CA 90501 USA

www.sevilleclassics.com

Please read and save these instructions

©2015 Seville Classics, Inc.

Please make sure you have all the parts before starting assembly.

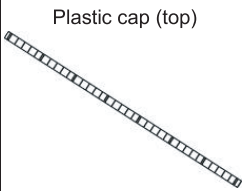
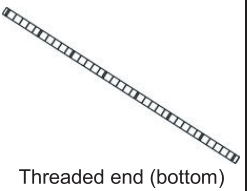
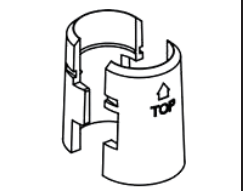
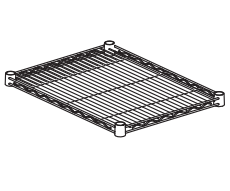
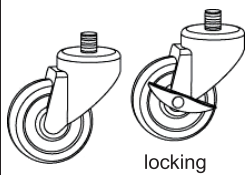
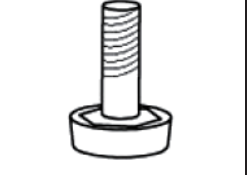
| | | | | | | | |
|---|---------|--|-------|---|----------|--|-------|
| A | 4 pcs | B | 4 pcs | C | 20 pairs | D | 5 pcs |
| Top Poles | | Bottom Poles | | Slip Sleeves | | Shelves | |
|  Plastic cap (top) | |  Threaded end (bottom) | |  | |  | |
| E | 2 pairs | F | 4 pcs | | | | |
| Wheels | | Leveling Feet | | | | | |
|  locking | |  | | | | | |

Step 1:
Screw **Wheels (E)** or **Leveling Feet (F)** into **Bottom Poles (B)**.

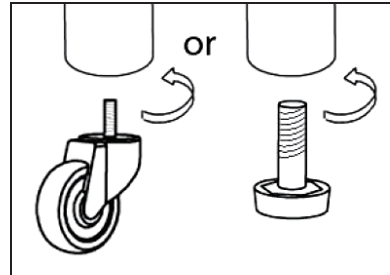

Step 2:
On the bottom of each pole, fasten a pair of **Slip Sleeves (C)** around the grooves at the desired shelf height.

Note: Double grooves are for sight

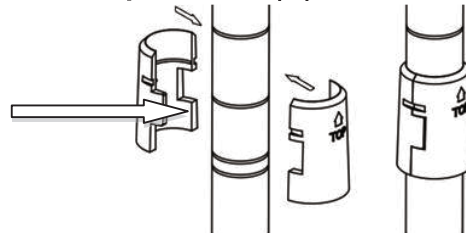

Step 3:
Slide a **Shelf (D)** over the top of 4 bottom poles until it rests snugly over the sleeves.

Tip: It is easier to do this step with the unit on its side. If necessary, use a rubber mallet to further secure the shelf.

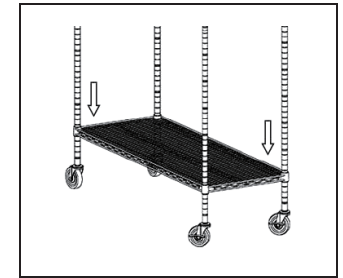

Step 4:
Repeat steps 2 and 3 by attaching slip sleeves and another shelf at the desired height.

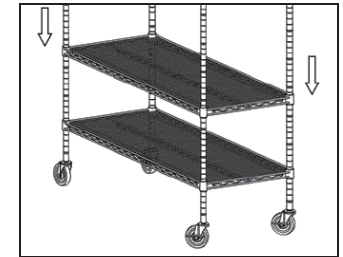

Step 5:
Once the unit is stable and upright, screw the **Top Poles (A)** into the bottom poles and add the remaining shelves to complete the unit.

