

Assembly Instructions

Approx. Dim.

Feria 4x4.2- Patio Cover

425L x 387W cm / 167.3"L x 152.4"W

Module Extention

181L x 387W cm / 71.3"L x 152.4"W

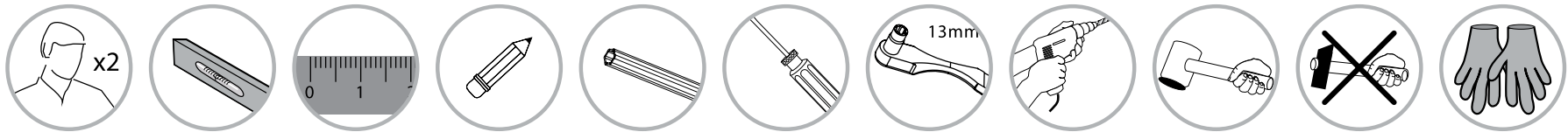

After Sale Service

Email: customer.service@palram.com

USA 877-627-8476
Canada 1 800-866-5749

England 01302-380775
Germany 0180-522-8778

France 0169-791-094
International +972 4-848-6942

www.palramapplications.com



Please read these instructions carefully before you start to assemble this product.
Please carry out the steps in the order set out in these instructions.
Keep these instructions in a safe place for future reference.



When encountering the information icon, please refer to the relevant assembly step for additional comments and assistance.



This icon indicates that the installer should be inside the product.

You will need

To assemble this product (these items not supplied)

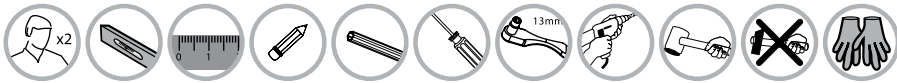

Safety

- Some parts may have sharp edges. Please be careful when handling components.
- Always wear gloves, eye protection, and long sleeves when assembling or performing any maintenance on your product.
- Do not attempt to assemble the product in windy or wet conditions.
To prevent injuries, do not allow children to play under the product during assembly.
- Do not climb or stand on the roof.
- Some versions of this product are painted.
If color was scratched during assembly it can be fixed with the following tints: White – RAL 9016, Gray – RAL 7012

Before Assembly

- This product is suitable for Palram's Patio Covers range
- Please consult your local authorities if any permits are required to construct the product.
- It is highly recommended to be assisted by a second person in some steps.
- Sort the parts and check according to the contents parts list.
- This product must be assembled on a solid base (such as concrete or asphalt) and anchored to the ground.
- Choose your site carefully before beginning assembly. Make sure that the mounting surface is leveled and clean from sharp objects in order to prevent scratches or damages to the product.
- Prior to the Extension installation, several parts from the Patio cover needs to be dismantle, it is recommend to keep them in a safe place for future need.

Product dimensions can be adjusted to your specific needs.

- ✓ The wall-mounting profile (top-back) can be adjusted from 260 to 305 cm (102.3" to 120") above ground. The adjusting is done when measuring and drilling (**step 12**).
- ✓ Poles distance from the wall can be adjusted from 310 to 370 cm (122" to 145.6").
The adjusting is done after assembly and before anchoring (**step 33**) by sliding poles and profile 7040 +7041 at channels of roof profiles.
- ✓ Poles distance from the side edges can be adjusted from 0 to 54 cm (0" to 21.3").
The adjusting is done after assembly and before anchoring (**step 33**) by sliding poles and connectors 937 at channel of profile 7040 +7041.

Note: Wall mounting and distance from the wall determine the roof angle and the total depth of the product (distance of gutter from the wall). Higher wall mounting and shorter distance between wall and poles increase the roof angle and shorten the total depth.

During Assembly

Steps/pages marked with dashed outline are referring to the extension kit assembly.(steps 4, 7,10,18 ,30 ,34)

These steps are referring to the installation of the extension kit on the right side of the patio cover; installation on the left side is possible according to same steps.

During assembly use a soft platform below the parts to avoid scratches and damages.

In case that you already own Palram Patio cover it is necessary to dismantle some parts and keep them for future use.

Step 4: Install plates #937 with part #7507 as described in **step 3**

Step 10: Install as described in **steps 8-9**

Step 18: Install as described in **steps 12-17**

Step 26: Make sure that the angle between the back wall profile and the panel supporting profiles is 90 degrees. Assembly of the panels should start from the middle of the patio cover to each side alternately.

Step 34: Please make sure that distance from the poles and the kit connection to original patio cover not exceeds 60 cm.

Tighten all screws when completing assembly.

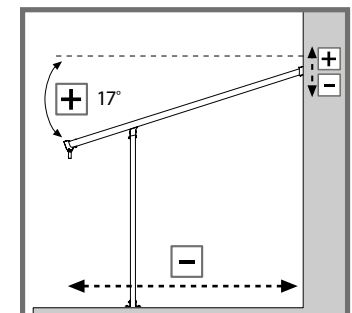
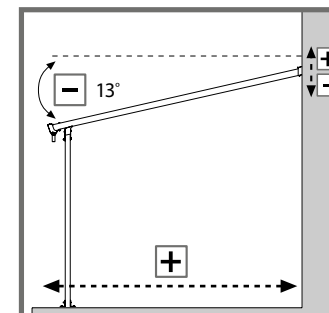
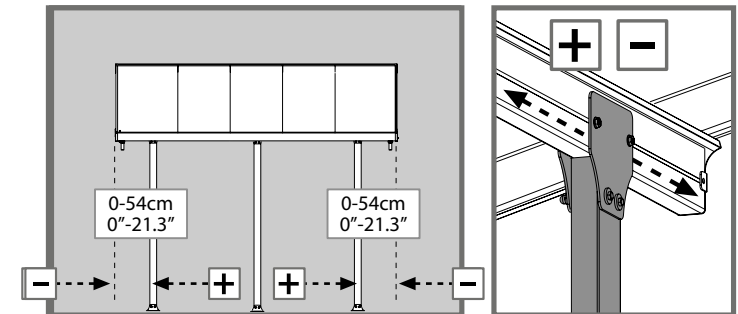
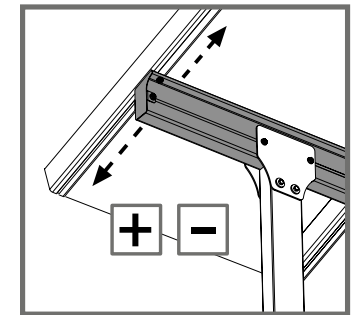
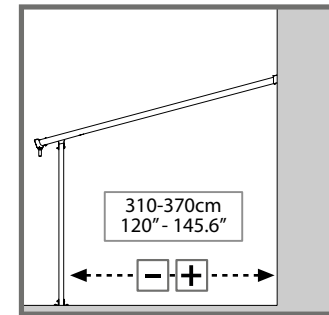
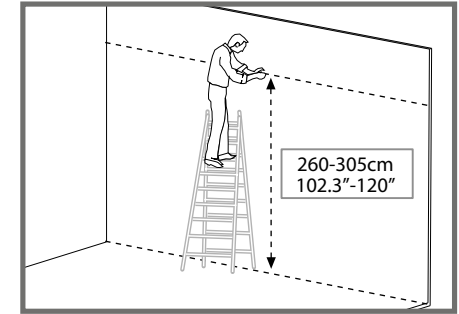

Merci de bien lire les instructions ci-dessous avant de commencer l'assemblage de ce toit de terrasse.



Veillez s'il vous plait exécuter les étapes d'assemblage dans l'ordre défini dans ces instructions.

Conservez ces instructions dans un endroit sûr pour référence ultérieure.



Lorsque vous rencontrez l'icône d'information, veuillez vous référer à l'étape d'assemblage appropriée pour toute remarque ou assistance additionnelle.



Cette icône indique que le constructeur doit se placer à l'intérieur du produit.

Vous aurez besoin

l'assemblage de ce produit (ces éléments ne sont pas fournis)

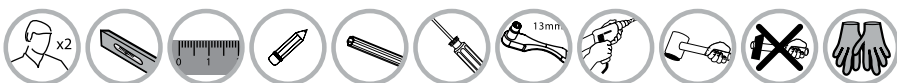

Sécurité

- Certaines pièces peuvent être coupantes. Soyez prudent lorsque vous manipulez les éléments.
- Porter toujours des gants, des lunettes de protection et des vêtements à manches longues lors de l'assemblage ou pendant toute opération de maintenance sur votre produit.
- Ne tentez pas de monter le produit dans des conditions venteuses ou humides. Pour éviter les blessures Ne laissez pas les enfants jouer autour et dans l'objet lors de l'assemblage.
- Ne pas grimper ou se tenir debout sur le toit.
- Certaines versions de ce produit sont peintes. Si la couleur a été rayée lors du montage ceci peut être fixé avec les teintes suivantes : Blanc – RAL 9016, Gris – RAL 7012

Avant l'assemblage

- Consultez s'il vous plait les autorités locales si un permis est nécessaire pour construire le produit.
- Il est vivement recommandé d'être assisté par une deuxième personne dans certaines étapes.
- Triez les pièces et vérifiez selon la liste de contenu.
- Il est impératif de fixer les poteaux sur un sol béton en utilisant le kit d'ancrage.
- Choisissez attentivement votre emplacement avant de commencer le montage. Assurez-vous que la surface de montage est nivelé Et qu'il n'y a pas d'objets pointus afin d'éviter des rayures ou dommages au produit.
- Plusieurs parties du couvercle Du toit de terrasse doivent être démontées avant l'installation de l'extension, il est recommandé de les garder dans un endroit sûr pour les besoins ultérieurs.

Note: Le montage sur le mur le réglage de la distance du mur déterminent l'angle du toit et la profondeur totale (distance de la gouttière du mur). Si le mur est monté plus en hauteur et si la distance entre le mur et les piliers est diminuée, l'angle du toit augmente et la profondeur totale est diminuée. Serrez toutes les vis après avoir achever l'assemblage. Il est recommandé, une fois la faitière posée, de mettre un joint en silicone (non fourni) afin d'assurer l'étanchéité et d'éviter ainsi toute infiltration d'eau entre le mur et la faitière.

Attention, en cas de non respect des recommandations de montage, la garantie ne pourra pas être appliquée.

Dimensions du produit peuvent être adaptées à vos besoins.

- ✓ Le Profil de fixation au mur (haut-arrière) peut être réglé à partir de 260 à 305 cm au dessus du sol.
- ✓ L'ajustement est effectué lors de la mesure et du perçage (**étape 12**)
La distance des pôles au paroi peut être réglée de 310 cm à 370 cm.
- ✓ L'ajustement est effectué après le montage et avant l'ancrage (**étape 33**) en glissant les poteaux et le profil 7040+7041 au rainures des profiles du toit.

La distance des pôles latéraux peut être réglée de 0 à 54 cm. L'ajustement est effectué après le montage et avant l'ancrage (**étape 33**) en glissant Les pôles et les connecteurs 937 aux rainures des profiles 7040+7041

Remarque: Le montage et la distance de la paroi détermine l'angle du toit et la profondeur totale du produit (la distance de la gouttière à la paroi). Un montage plus haut et une distance plus courte entre la paroi et les pôles augmentent l'angle du toit et raccourcissent la profondeur du produit.

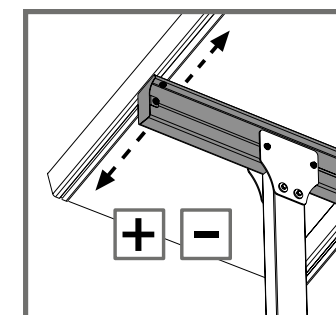
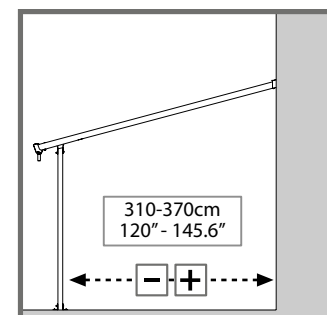
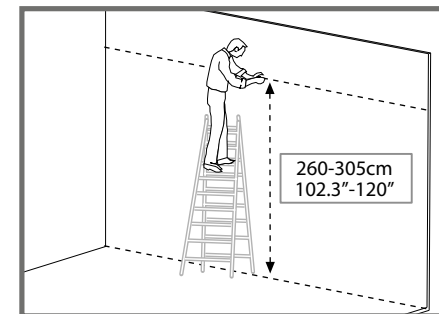

Pendant l'Assemblage

Étapes/pages marquées avec un contour en pointillés font référence à l'assemblage du Kit d'extension (étapes 4,7,10,18,30,34)

Ces étapes se réfèrent à l'installation du kit d'extension sur le côté droit du Toit de terrasse; installation du côté gauche est possible selon les mêmes étapes.

Lors du montage, utilisez une plate-forme souple en dessous des pièces pour éviter les rayures et les dommages.

Dans le cas où vous auriez déjà un toit de terrasse, il serait nécessaire de démonter les pièces et de les garder pour une utilisation ultérieure.

Étape 4 : Installez les lamelles #937 avec la pièce #7507 comme décrit dans l'étape 3

Étape 10 : installer comme décrit dans les étapes 8-9

Étape 18 : installer comme décrit dans les étapes 12-17

Étape 26 : installer-vous que l'angle entre le profile paroi arrière et le panneau de support des profiles est à 90 degrés.

L'assemblage des panneaux doit commencer à partir du milieu du Toit de terrasse, de chaque côté en alternance.

Étape 34 : Assurez-vous que la distance des pôles et le kit connexion à votre couvre patio initiale ne dépasse pas les 60 cm.

Renforcez toutes les vis dès que l'assemblage est achevé

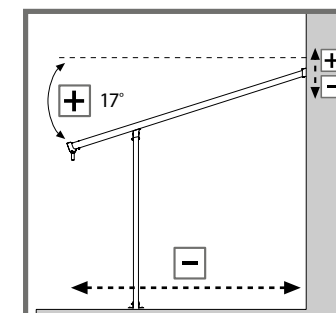
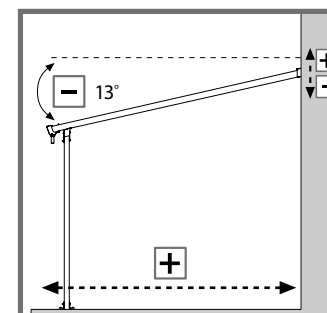
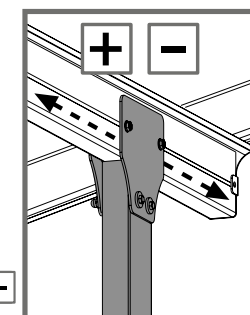
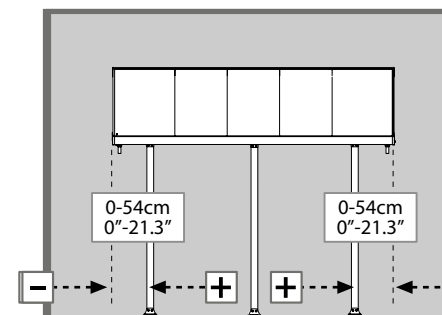



Anmerkung: Bitte lesen Sie diese Anleitungen sorgfältig durch, bevor Sie mit dem Aufbau dieses Produktes beginnen. Bitte führen Sie die Schritte aus, wie sie in der Reihenfolge dieser Anleitung angegeben werden. Bewahren Sie diese Anleitung an einem sicheren Ort auf für späteres Nachschlagen



Wenn Sie dieses Infozeichen Begegnen, dann achten Sie bitte bei dem entsprechenden Montageschritt auf zusätzliche Kommentare und Helfende Zusatzinformation



Dieses Symbol zeigt an, dass der Einbauer im Innenraum des Produktes sein sollte

Sie benötigen

Sie benötigen folgendes für den Aufbau dieses Produktes

(Diese Gegenstände sind nicht enthalten).

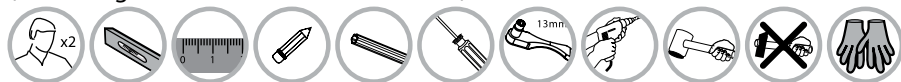

Sicherheit

- Einige Teile haben scharfe Kanten. Bitte gehen Sie beim Anfassen der Teile vorsichtig vor.
- Tragen Sie beim Aufbau oder beim Arbeiten an dem Produkt stets Augenschutz und lange Ärmel
- Versuchen Sie nicht, das Produkt in windigem oder regnerischem Wetter zu montieren.
- Um Unfälle zu vermeiden sollten Kinder davon abgehalten werden unter dem Produkt zu spielen..
- Einige Versionen dieses Produktes sind lackiert. Sollte die Farbe bei der Montage verkratzen, kann es mit den folgenden Farben nachlackiert werden: Weiss - RAL 9016 Grau - RAL 7012

Vor Beginn der Montage

- Fragen Sie bei Ihren örtlichen Behörde nach, ob irgendwelche Genehmigungen erforderlich sind, um das Produkt zu bauen.
- Es wird dringend empfohlen, von einer zweiten Person in einigen Schritten assistiert zu werden.
- Sortieren Sie die Teile aus und prüfen Sie diese nach dem Inhaltverzeichnis.
- Das Produkt muss auf einer ebenen Oberfläche (wie Beton oder Asphalt) positioniert und fixiert werden.
- Wählen Sie Ihren Ort sorgfältig aus, bevor Sie mit der Montage beginnen.
- Stellen Sie sicher, dass die Montagefläche nivelliert und frei von scharfen Gegenständen ist, um Kratzer oder Schäden an das Produkt zu vermeiden.
- Vor der Installation, müssen mehrere Teile aus der Patio Abdeckung abmontiert werden, es wird empfohlen, diese an einem sicheren Ort für den zukünftigen Gebrauch aufzubewahren.

Die Produktgröße kann auf Ihre speziellen Bedürfnisse angepasst werden.

- ✓ Bei der Wandmontage kann das Profil (Oben hinten) von 260 cm bis auf 305 cm (102.3" bis 120") über dem Boden angepasst werden.
- ✓ Die Verstelleinrichtung erfolgt, bei der Messung und beim Bohren (**Schritt 12**). Der Pfostenabstand von der Wand darf zwischen 310 cm und 370 cm sein (122" bis 145.6").

Die Verstelleinrichtung wird nach der Montage und vor der Ankerung gemacht (**Schritt 33**), indem die Pfosten und Profil 7040 + 7041 an den Kanälen des Dach Profils eingeführt werden.

- ✓ Pfostenabstand von den Seitenkanten kann von 0 bis auf 54 cm eingestellt werden (0" auf 21.3"). Die Verstelleinrichtung wird nach der Montage und vor der Ankerung gemacht (**Schritt 33**), indem die Pfosten und Verbindungsstück 937 an Profilkanal 7040 + 7041 eingeführt werden

Hinweis: Wandmontage und Abstand von der Wand bestimmen die Dachneigung und die gesamte Tiefe des Produktes (Abstand der Dachrinne von der Wand). Höhere Wandmontage und kürzeren Abstand zwischen Wand und Pfosten erhöhen die Dachneigung und verkürzen die gesamte Tiefe.

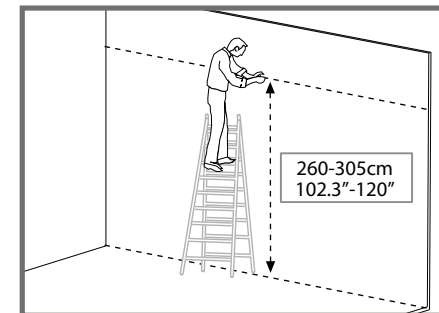

Während der Montage

Die Schritte / Seiten, die mit gestrichelten Linien markiert sind, beziehen sich auf die Montage des Erweiterungsset (Schritte 4, 7, 10, 18, 30, 34)

Diese Schritte beziehen sich auf die Installation des Verlängerungssets auf der rechten Seite, ist die Installation auf der linken Seite kann gemäß gleicher Schritte fortgesetzt werden.

Bei der Montage nehmen Sie eine weiche Plattform und stellen Sie diese unterhalb der Teile, um Kratzer und Beschädigungen zu vermeiden
 Falls Sie bereits eine Palram Patio - Abdeckung besitzen, ist es notwendig einige Teile abzumontieren und diese für den zukünftigen Gebrauch aufzubewahren.

Schritt 4: Installieren Sie Platten # 937 mit dem Teil # 7507 wie im **Schritt 3** beschrieben wird

Schritt 10: Installieren Sie wie in den **Schritten 8-9** beschrieben wird

Schritt 18: Installieren Sie wie in den **Schritten 12-17** beschrieben wird.

Schritt 26: Stellen Sie sicher, dass der Winkel zwischen der Rückwand profil und die Plattentragprofilen 90 Grad beträgt. Die Montage der Paneele sollte aus der Mitte der Patio - Abdeckung nach außen erfolgen, auf jeder Seite abwechselnd.

Schritt 34: Bitte stellen Sie sicher, dass zwischen den Pfosten und Verbindungsset an die ursprüngliche Patio Abdeckung die Entfernung von 60 cm nicht überschritten wird

Ziehen Sie alle Schrauben fest an, nach dem Sie die Montage beendet haben.

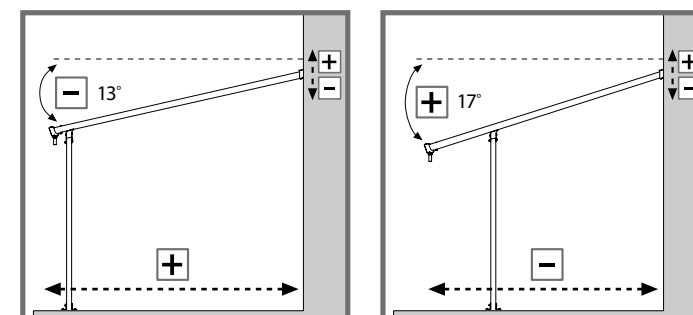
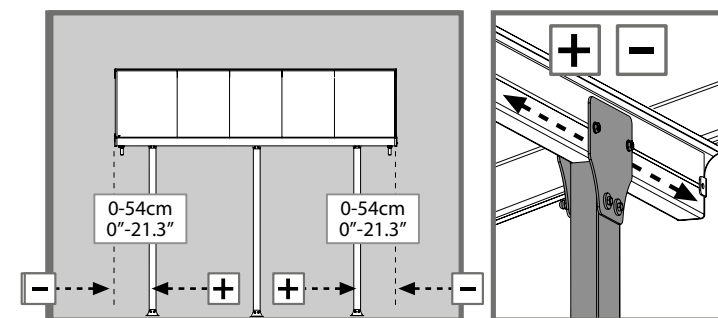
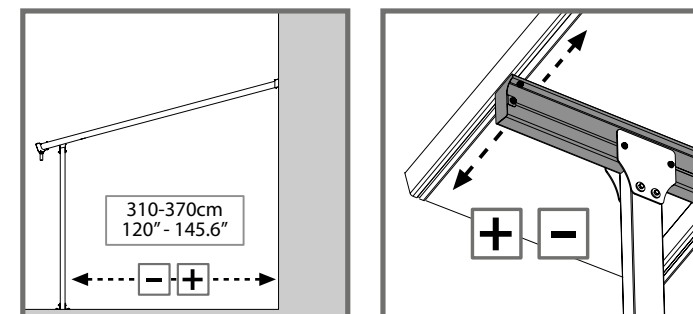



Por favor, lea atentamente estas instrucciones antes de empezar a ensamblar el producto.
Lleve a cabo los pasos en el orden indicado en estas instrucciones.
Guarde las instrucciones en un lugar seguro para futuras consultas.



Cuando vea el icono de información, consulte el paso de montaje correspondiente para obtener comentarios adicionales y asistencia.



Este icono indica que el instalador debe estar dentro del producto.

Lo que necesitará

Para ensamblar este producto (estos artículos no están incluidos).

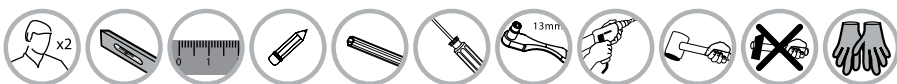

Seguridad.

- Algunas piezas pueden tener bordes filosos. Tenga cuidado al manejar los componentes.
- Siempre use guantes, protección para los ojos y mangas largas cuando esté ensamblando o realizando el mantenimiento de su producto.
- No intente ensamblar el producto en condiciones de viento o humedad. Para evitar lesiones, no permita que los niños jueguen debajo del producto durante su montaje.
- No se trepe ni se pare sobre el techo.
- Algunas versiones de este producto vienen pintadas. Si la pintura se rasga durante el montaje, puede ser reparada con los siguientes tintes:
Blanco - RAL 9016, Gris - RAL 7012

Antes del Montaje

- Consulte con las autoridades locales si es necesario obtener algún permiso para construir el producto.
- Es muy recomendable que sea asistido por otra persona en algunos de los pasos de la instalación.
- Ordene las piezas y verifíquelas de acuerdo con el índice de contenido.
- Este producto debe ser montado sobre una base sólida (como ser hormigón o asfalto) y anclado al suelo.
- Antes de comenzar el montaje, elija el sitio con cuidado. Asegúrese de que la superficie de montaje esté nivelada y libre de objetos afilados para evitar arañazos o daños al producto.
- Antes de la instalación, algunas partes de la cubierta del Patio deben ser desarmadas, se recomienda guardarlas en un lugar seguro para necesidades futuras.

Es posible ajustar las dimensiones del producto a sus necesidades específicas.

- ✓ El perfil de fijación mural (parte superior y posterior) se puede ajustar desde 285 hasta 305 cm (112.2" hasta 120") desde el suelo.
- ✓ El ajuste se realiza en la etapa de medición y perforación (**paso 12**).
La distancia de los postes a la pared se puede ajustar desde 310 cm hasta 370 cm (122" hasta 145.6").
- ✓ El ajuste se realiza después del montaje y antes del anclaje (**paso 33**), deslizando los postes y los perfiles 7040 y 7041 en los canales de los perfiles del techo.
La distancia de los bordes laterales puede ser ajustada desde 0 cm hasta 54 cm (0" hasta 21.3"). Los ajustes se hacen después del montaje y antes del anclaje (**paso 33**) mediante el deslizamiento de los postes y los conectores 937 al canal del perfil 7040 +7041.

Nota: La fijación mural y la distancia desde la pared determinan el ángulo del techo y la profundidad total del producto (la distancia entre el muro y el canalón). Una fijación mural más alta y una menor distancia entre el muro y los postes aumentan el ángulo del techo y acortan su profundidad total.

Durante el Montaje

Los pasos/páginas subrayados con una línea entrecortada se refieren al kit de montaje de la extensión.
(Los pasos 4, 7, 10, 18, 30, 34)

Estos pasos se refieren a la instalación del kit de extensión del lado derecho de la cubierta del patio; es posible instalarlo del lado izquierdo, siguiendo los mismos pasos.

Durante el montaje, coloque las piezas sobre una superficie suave para evitar arañazos y daños.

Si usted ya tiene una cubierta de patio de Palar, será necesario que desarme algunas partes y que las guarde para usarlas en el futuro.

Paso 4: Instale los paneles nº937 con la pieza nº7507 como se describe en el **paso 3**

Paso 10: Instale como se describe en los **pasos 8-9**

Paso 18: Instale como se describe en los **pasos 12-17**

Paso 26: Asegúrese de que el ángulo entre el perfil de la pared trasera y los perfiles de soporte del panel sea de 90 grados. El montaje de los paneles debe comenzar desde el centro de la cubierta del patio hacia cada lado, alternativamente.

Paso 34: Asegúrese de que la distancia entre los postes y el kit de conexión a la cubierta de patio original no exceda los 60 cm.

Cuando termine el montaje, apriete bien todos los tornillos.

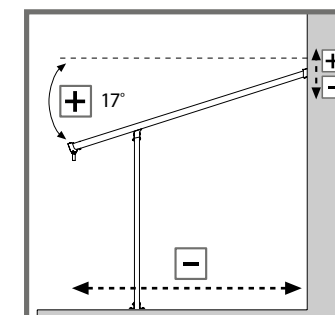
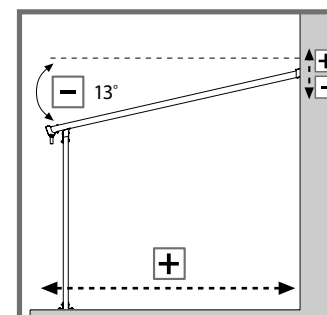
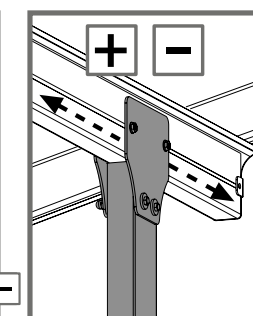
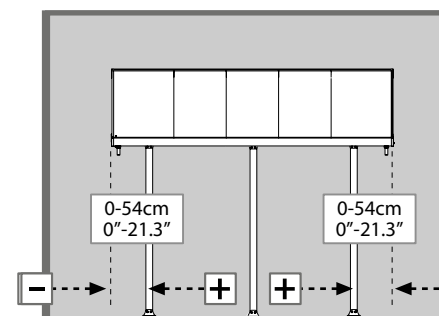
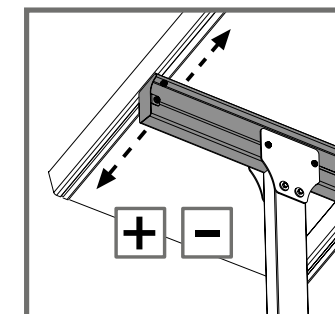
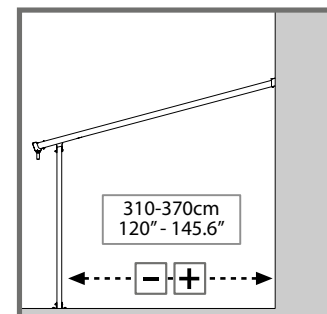
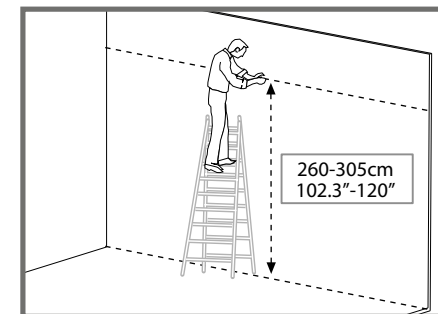

DŮLEŽITÉ

Přečtěte si, prosím, pečlivě tyto instrukce před tím, než začnete sestavovat tento kryt na terasu. Postupujte, prosím, podle kroků v uvedeném pořadí. Ponechte tyto instrukce na bezpečném místě pro budoucí potřebu.



Když narazíte na informační ikonu, přejděte, prosím, na patřičný krok montáže pro další komentáře a pomoc.



Tato ikona naznačuje, že montér by měl být uvnitř výrobku.

Budete potřebovat

Pro montáž tohoto výrobku (tyto položky nejsou dodávány)

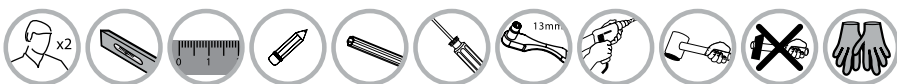
**Bezpečnost**

- Některé části mohou mít ostré hrany. Buďte, prosím, při zacházení s nimi opatrní.
- Při montáži nebo údržbě vašeho produktu vždy noste rukavice, ochranu očí a dlouhé rukávy.
- Nepokoušejte se sestavit tento výrobek za větrných nebo vlhkých podmínek. Především zranění a nenechte děti, aby si během montáže hrály pod výrobkem.
- Nelezte na střechu, ani na ní nestůjte.
- Některé verze tohoto výrobku jsou natřené. Pokud je během montáže poškrábána barva, můžete to opravit následujícími odstíny: Bílá – RAL 9016, Šedá – RAL 7012

Před montáží

- Tento výrobek je vhodný pro řadu Krytů na terasy Palram
- Pokud jsou pro postavení tohoto výrobku nutná povolení, pak, prosím, kontaktujte místní úřady.
- Velmi doporučujeme, aby vám při některých krocích pomáhala druhá osoba.
- Seřadte si součásti a zkontrolujte je podle seznamu součástí.
- Tento výrobek musí být zmontován na pevném povrchu (jako například beton nebo asfalt) a ukotven k zemi.
- Před zahájením montáže si pečlivě vyberte prostor. Ujistěte se, že je jeho povrch vyrovnaný a neobsahuje žádné ostré předměty, které by mohly poškodit tento výrobek.
- Před montáží Přístavby musí být rozebráno několik součástí tohoto Krytu na terasu. Doporučujeme, abyste je ponechali na bezpečném místě pro budoucí potřebu.

Rozměry výrobku mohou být přizpůsobeny vašim specifickým potřebám

- ✓ Profil pro uchycení na zeď (vzadu nahore) může být upraven z 260 na 305 cm (102.3" na 120") nad zemí. Tato úprava se provádí během měření a vrtání (**krok 12**).
- ✓ Vzdálenost tyčí ode zdi může být upravena z 310 na 370 cm (122" na 145.6"). Tato úprava se provádí po montáži a před ukotvením (**krok 33**) posunutím tyčí a profilu 7040 +7041 na kanálech střešních profilů.
- ✓ Vzdálenost tyčí od bočních rohů může být upravena z 0 na 54 cm (0" na 21.3"). Tato úprava se provádí po montáži a před ukotvením (**krok 33**) posunutím tyčí a konektorů 937 na kanálech profilu 7040 +7041.

Poznámka: Upevnění ke zdi a vzdálenost ode zdi rozhodují o úhlu střechy a celkové hloubce výrobku (vzdálenost okapu ode zdi). Vyšší upevnění ke zdi a menší vzdálenost mezi zdi a tyčemi zvětší úhel střechy a sníží celkovou hloubku.

Během montáže

Kroky/stránky označené čárkovaným rámcem odkazují na montáž prodlužovací sady (kroky 4, 7, 10, 18, 30, 34)

Tyto kroky odkazují na instalaci prodlužovací sady na pravou stranu tohoto přístřešku na terasu. Instalace na levou stranu je možná podle stejných kroků.

Během montáže použijte dole měkkou plochu, abyste zabránili poškrábání a poškození součástí.

V případě, že již vlastníte kryt na terasu Palram, je nutné rozmontovat některé součásti a ponechat je pro budoucí použití.

Krok 4: Nainstalujte desky #937 s částí #7507 tak, jak je popsáno v **kroku 3**

Krok 10: Nainstalujte tak, jak je popsáno v **krocích 8-9**

Krok 18: Nainstalujte tak, jak je popsáno v **krocích 12-17**

Krok 26: Ujistěte se, že úhel mezi profilem zadní zdi a panelem podporujícím profily je 90 stupňů.

Montáž těchto panelů musí začít od prostředního krytu terasy střídavě na každou stranu.

Krok 34: Ujistěte se, prosím, že vzdálenost od tyčí a připojení sady k originálnímu krytu terasy nepřekročí 60 cm.

Po dokončení montáže utáhněte všechny šroubky.

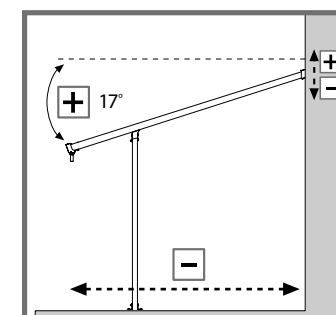
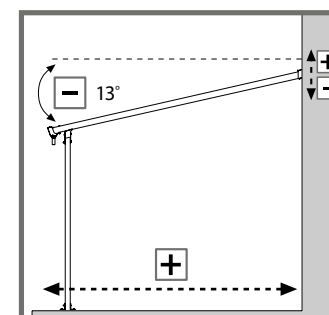
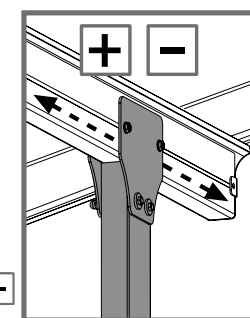
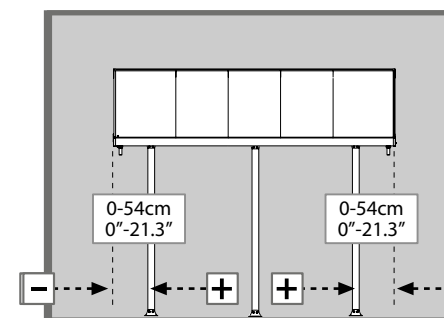
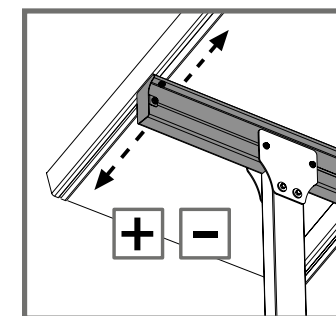
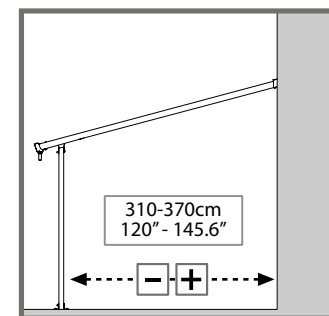
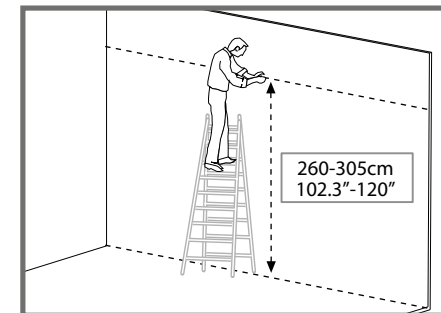



Læs vejledningen omhyggeligt, inden du påbegynder montering af dette produkt.
Udfør trinene i den rækkefølge, de er beskrevet i vejledningen.
Opbevar vejledningen på et sikkert sted.



Når du møder informationsikonet, gå hen til det relevante monteringstrin for yderligere assistance og kommentarer.



Denne ikon betyder, at montøren skal være inde i produktet.

Du skal bruge

For at montere dette produkt (disse artikler leveres ikke)

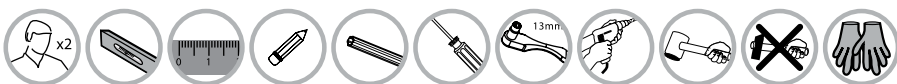

Sikkerhed

- Nogle af delene kan have skarpe kanter. Udvis forsigtighed ved håndtering af delene.
- Hav altid handsker på samt påklædning med lange ærmer og beskyttelsesbriller, når du monterer eller laver vedligeholdelsesarbejde på produktet.
- Prøv ikke at montere produktet under blæsende eller våde vejrforhold.
- For at undgå skader lad ikke børn lege under produktet under monteringen.
- Kravl ikke op på taget og stå ikke på taget.

Nogle typer af dette produkt er malet.

Hvis malingen er blevet beskadiget under monteringen, kan den udbedres med følgende farvenuancer: Hvid – RAL 9016, grå – RAL 7012

Inden montering

- Kontakt de lokale myndigheder, hvis der kræves tilladelse til at bygge produktet.
- Det anbefales – for nogle af trinene – at få assistance fra en anden person.
- Sorter delene og afstem dem efter listen af dele.
- Dette produkt passer til Palrams udvalg af terrasse-udhæng.
- Produktet skal samles på et solidt underlag (som f.eks. beton eller asfalt) og skal gøres fast til jorden.
- Vælg stedet omhyggeligt, inden monteringen påbegyndes. Sørg for at monteringsfladen er plan og fri for skarpe genstande for at undgå ridser og beskadigelse af produktet.
- Inden montering af udvidelsesmodulet skal flere dele fra terrasse-udhænget afmonteres, og det anbefales at opbevare disse dele på et sikkert sted til senere brug.

Produkt-dimensionerne kan tilpasses dine specifikke behov

- ✓ Pladen, som skal monteres på væggen (øverst bagtil), kan justeres fra 260 til 305 cm over jorden. Justering skal ske under afmålings- og borearbejdet (trin 12).
- ✓ Pælens afstand fra væggen kan justeres fra 310 til 370 cm.
- ✓ Justering skal ske efter montering, men inden forankring (trin 33) ved at lade pælene og profilerne 7040 + 7041 glide i renderne på tagpladerne.
- ✓ Pælens afstand fra sidens kant kan justeres fra 0 til 54 cm. Justering skal ske efter montering, men inden forankring (trin 33) ved at lade pælene og forbindelserne 937 glide i renden på pladerne 7040 + 7041.

Bemærk: Vægmontering og afstanden fra væggen afgør tagets vinkel og dybden af produktet (tagrendens afstand fra væggen). Monteringshøjden på væggen og kortere afstand mellem væggen og pælene forstørrelse tagvinklen og afkorter den totale dybde.

Under montering

Trin/sider mærket med stiplede linje henviser til montering af udvidelsesmodul (trin 4, 7, 10, 18, 30, 34). Disse trin henviser til montering af udvidelsesmodulet på terrasse-udhængets højre side. Montering på venstre side er mulig (følg samme trin).

Under montering sørg for at lægge et blødt underlag under delene for at undgå ridser og beskadigelse af delene.

Hvis du allerede har et Palram terrasse-udhæng, er det nødvendigt at afmontere nogle af delene og opbevare dem til senere brug.

Trin 4: Monter plade #937 med del #7507 som beskrevet i trin 3

Trin 10: Monter som beskrevet i trin 8-9

Trin 18: Monter som beskrevet i trin 12-17

Trin 26: Konstatér at vinklen mellem den bageste vægplade og de plader, som understøtter panelet, er 90 grader. Montering af pladerne skal starte fra midten af terrasse-udhænget til hver side skiftevis.

Trin 34: Konstatér at afstanden fra pælene og udvidelsesmodulet til det oprindelige terrasse-udhæng ikke overstiger 60 cm.

Fastgør alle skruer, når monteringen er tilendebragt.

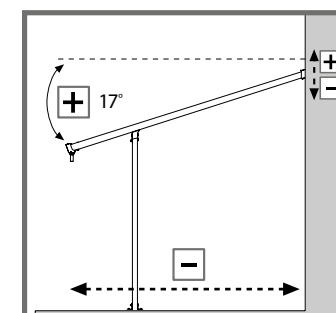
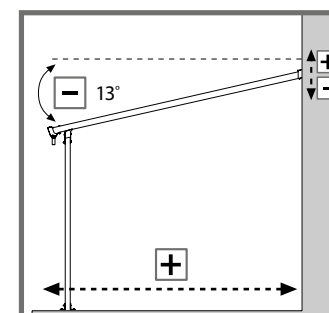
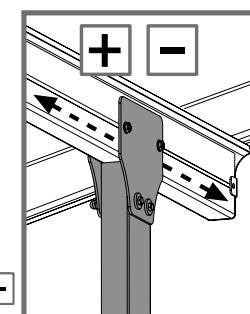
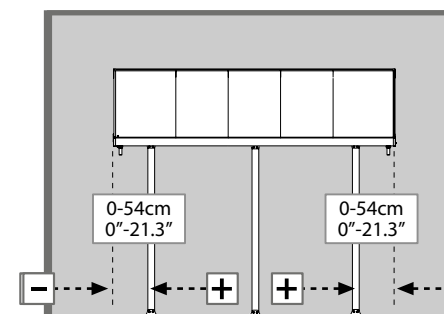
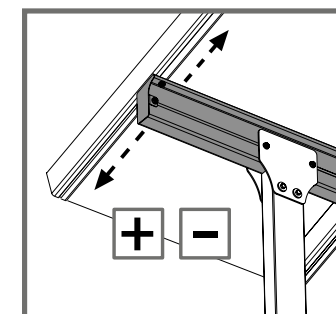
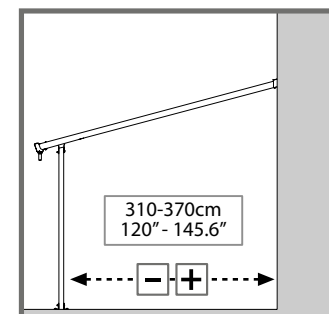
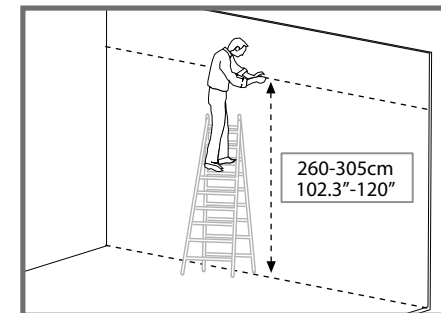

BELANGRIJK

Lees de volgende instructies aandachtig voordat u deze patio cover begint te monteren. Voer de stappen uit in de volgorde vermeld in deze instructies. Bewaar deze instructies op een veilige plaats voor latere referentie.



Als u een informatiepictogram opmerkt, lees dan de relevante montage­stap voor extra opmerkingen en hulp.



Dit pictogram geeft aan dat de installateur in het product moet staan.

Wat u nodig hebt om

Dit product te monteren (deze zaken worden niet meegeleverd)

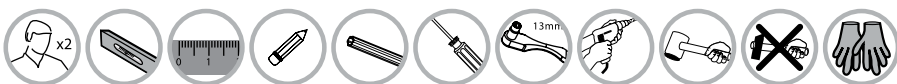
**Veiligheidsrichtlijnen**

- Sommige onderdelen hebben metalen randen. Wees voorzichtig bij het hanteren van de componenten.
- Draag steeds handschoenen, schoenen en een veiligheidsbril tijdens de montage.
- Tracht het product niet te monteren bij winderig of nat weer. Verwijder alle plastic zakken op een veilige manier – houd ze uit de buurt van kleine kinderen.
- Klim niet op het dak en ga er niet op staan.
- Sommige parts van dit product zijn geveerd. Als er krassen komen in de kleur tijdens de montage, kan dit hersteld worden met de volgende tinten: wit – RAL 9016 grijs –RAL 7012

Voor het starten van de montage

- Raadpleeg de lokale autoriteiten of u vergunningen nodig hebt om het product te monteren.
- Om veiligheidsredenen raden we aan dat het product gemonteerd wordt door minstens twee personen.
- Sorteert de onderdelen en controleer de inhoudslijst.
- Deze carport moet een stevige ondergrond (zoals beton of asfalt) gemonteerd worden.
- Kies uw site zorgvuldig voordat u begint met de montage. Zorg ervoor dat het montagevlak wordt geëgaliseerd en vrij van scherpe voorwerpen om krassen of beschadigingen te voorkomen aan het product.
- Leg tijdens de montage de onderdelen op een zacht platform om krassen en beschadiging te voorkomen.

De productafmetingen kunnen aangepast worden naar uw specifieke vereisten

- ✓ Het wandmontageprofiel (boven - achter) kan aangepast worden van 260 tot 305 cm (102.3" tot 120" boven de grond. De aanpassing gebeurt bij het meten en boren (**stap 12**).
- ✓ De afstand van de palen tot de wand kan aangepast worden van 310 tot 370 cm (122" tot 145.3/5"). De aanpassing gebeurt na de montage en vóór de verankering (**stap 33**) door de palen en het profiel 7040 +7041 te verschuiven in de gleuven van de dakprofielen
- ✓ De afstand van de palen tot de zijkanten kan aangepast worden van 0 tot 54 cm (0" tot 21 1/4"). De aanpassing gebeurt na de montage en vóór de verankering (stap 33) door de palen en de verbindingen 937 te verschuiven in de gleuf van profiel 7040 +7041.

Opmerking: Wandmontage en afstand van de wand bepalen de dakhoek en de totale diepte van het product (afstand tot de goot vanaf de wand). Een hogere wandmontage en kortere afstand tussen de wand en de palen vergroten de dakhoek en verkleinen de totale diepte.

Tijdens de montage

Stappen/pagina's gemarkeerd met een stippelijijn verwijzen naar de montage van het uitbreidingspakket. (stappen 4, 7, 10, 18, 30, 34)

Deze stappen verwijzen naar de installatie van het uitbreidingspakket aan de rechterkant van de patio cover; installatie aan de linkerkant is mogelijk door dezelfde stappen te volgen.

Leg tijdens de montage de onderdelen op een zacht platform om krassen en beschadiging te voorkomen.

In geval u al over een Palram Patio cover beschikt, is het nodig om sommige onderdelen te demonteren en ze op een veilige plaats te bewaren voor later gebruik.

Step 4: installeer de platen #937 met onderdeel #7507 zoals beschreven in **stap 3**

Step 10: installeer zoals beschreven in **stappen 8-9**

Step 18: installeer zoals beschreven in **stappen 12-17**

Step 26: zorg ervoor dat de hoek tussen het achterwandprofiel en de profielen die het paneel ondersteunen 90 graden is. De montage van de panelen moet beginnen vanuit het midden van de patio cover naar beide kanten afwisselend

Step 34: zorg ervoor dat de afstand van de palen en het verbindingstuk van het pakket tot de oorspronkelijke patio cover niet groter is dan 60 cm.

Draai alle schroeven vast bij het voltooiën van de montage.

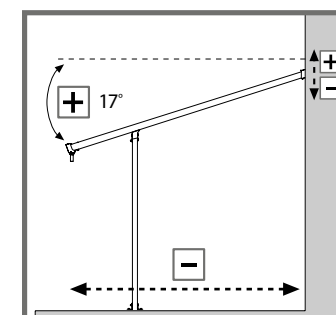
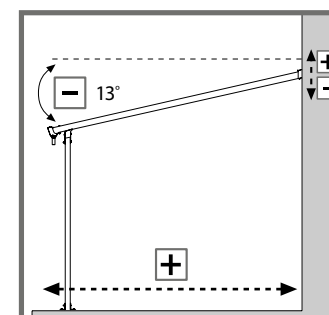
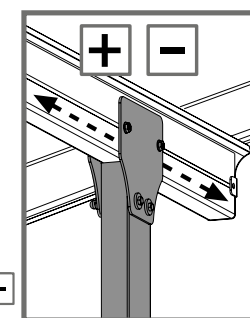
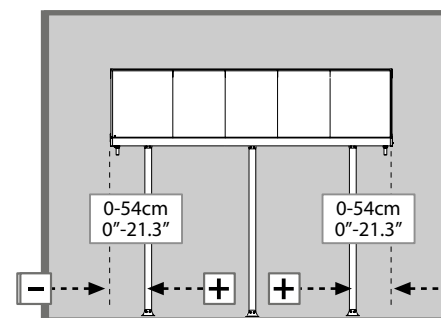
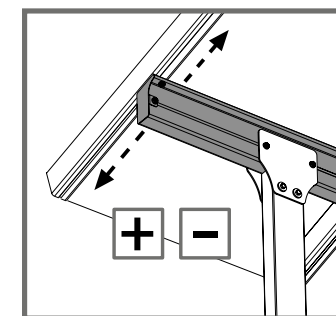
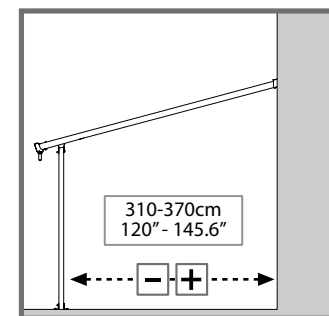
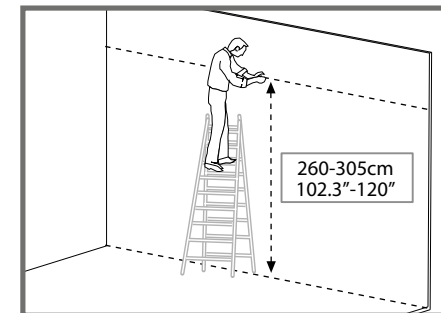

SVARBU

Prieš pradėdami rinkti gaminį, perskaitykite šią instrukciją. Instrukciją laikykite saugioje vietoje, kad vėliau galėtumėte ja pasinaudoti.

Priežiūros ir saugos reikalavimai

- vykdykite nurodymus pagal šią instrukciją.
- Surūšiuokite dalis ir patikrinkite jas pagal sąrašą.
- Saugos sumetimais rekomenduojama gaminį rinkti bent dviem asmenims.
- Kai kurių dalių briaunos yra metalinės. Būkite itin atidūs naudodami pavienes dalis.
- Rinkdami visada mūvėkite pirštines, avėkite batus ir užsidėkite apsauginius akinius.
- Nerinkite gaminio esant vėjui ar drėgnam orui.
- Saugiai pašalinkite visus plastikinius maišus arba laikykite juos vaikams nepasiekiamoje vietoje.
- Į surinkimo vietą neleiskite vaikų.
- Nerinkite gaminio pavargę, pavartoję alkoholio, narkotikų ar vaistų, svaigstant galvai.
- Saugiai pašalinkite visus plastikinius maišus arba laikykite juos vaikams nepasiekiamoje vietoje.
- Į surinkimo vietą neleiskite vaikų.
- Nerinkite gaminio pavargę, pavartoję alkoholio, narkotikų ar vaistų, svaigstant galvai.
- Lipdami ant laiptinių kopėčių ar naudodami elektrinius įrankius, vadovaukitės gamintojo saugos reikalavimai.
- Nelipkite ir nestovėkite ant stogo.
- Neremkite į polių sunkių daiktų.
- Nekybokite ir negulėkite ant profilių.
- Savivaldybės įstaigose pasiteiraukite, ar šio gaminio statybai nereikia leidimo.
- Nuo stogo ir latakų pašalinkite sniegą, purvą ir lapus.
- Ant stogo susikaupęs sniegas gali sugadinti gaminį ir kelti pavojų po juo ar šalia stovintiems asmenims
- Šis gaminys naudojamas kaip terasos stogas. Kai kurie šio gaminio detalės nudažytos. Jei surinkimo metu dažai susibraižo, dangą galima atkurti naudojant „White-RAL 9016“, „Gray-RAL7012“.

Valymas

Gaminį valykite švelniu plovikliu, perplaukite šaltu švariu vandeniu.

Plokštėms valyti nenaudokite acetono, abrazyvinių ar kitų specialių valiklių.

Prieš surinkimą

- Gaminys turi būti statomas ant kieto pagrindo (pvz., betoninio).
- Prieš pradėdami darbus, atidžiai pasirinkite vietą. Žemės paviršius (ypač tarp polių) turi būti išlygintas
- Surinkimo metu dalis sudėkite ant minkšto pakloto, kad jos nesusibraižytų.

Matmenų reguliavimas

Gaminio matmenys gali būti reguliuojami pagal poreikius.

1. Prie sienos montuojamo profilio aukštį galima reguliuoti 285 – 305 cm intervalu nuo žemės paviršiaus.
2. Polių atstumą nuo sienos galima reguliuoti 226 – 286 cm intervalu.
3. Reguluoti surinkus, tačiau prieš pritvirtinant gaminį (26 veiksmas). Reguluojant polių ir profilį (7040 + 7041) stumdyti stogo profilių kanalais.

4. Polių atstumą nuo šoninių briaunų galima reguliuoti 0 – 54 cm intervalu. Reguluoti surinkus, tačiau prieš pritvirtinant gaminį (26 veiksmas). Reguluojant polių ir 937 jungtis (70407041+) stumdyti stogo profilių kanalais

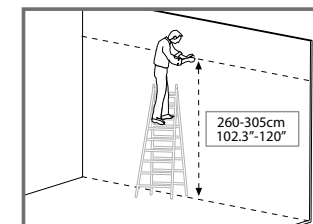

Pastabos. Nuo tvirtinimo prie sienos aukščio bei polių atstumo nuo sienos priklauso stogo nuolydis ir bendras gaminio gylis (latakų atstumas nuo sienos). Jeigu montuojama aukščiau, o tarp sienos ir polių yra mažesnis atstumas, stogo nuolydis bus didesnis, o visas gylis mažesnis. Baigus rinkti, priveržti visus varžtus.

Reguluojama matuojant ir gręžiant (9 veiksmas).

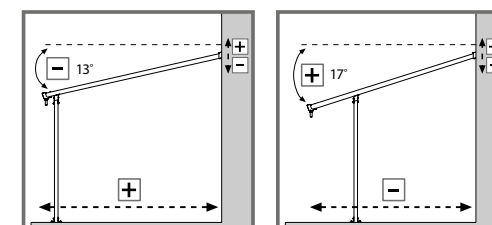
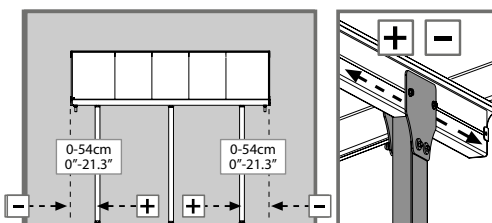
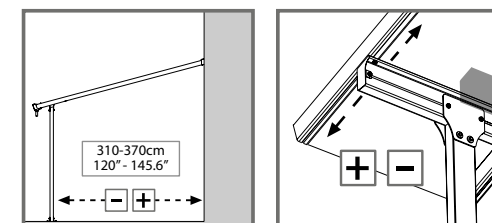

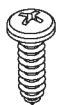

Contents

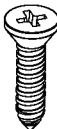
447  12 (+1)

8708  16 (+1)

411  46 (+6)
M6

466  46 (+6)
M6

Item Qty.
433  45 (+2)
M8

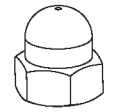
414  12 (+1)
M8

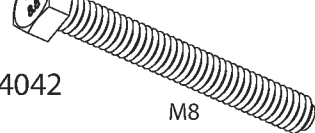
4042  12 (+1)
M8

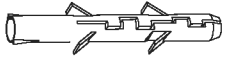
4010  21 (+1)

5000  12

4000  21 (+1)

Item Qty.
7335  2 (+1)

7294  1

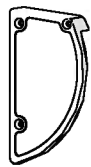
7295  1

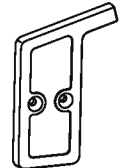
7296  1

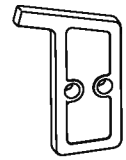
7297  1

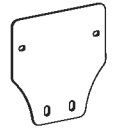
937  6

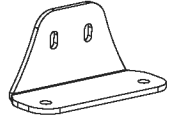
Item Qty.
212  6

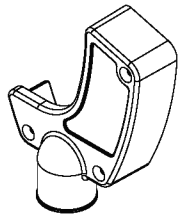
7028  1

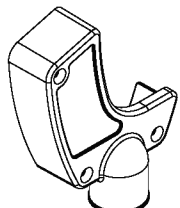
7027  1

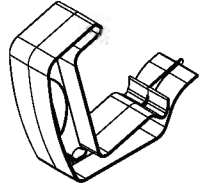
7029  1

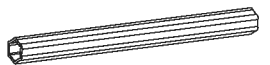
Item Qty.
T001  1

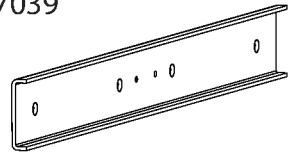
7039  2

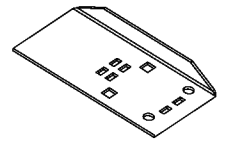
7038  6

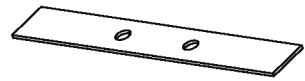
7334  1

Contents

Item	Qty.
7041	1
7040	1

Item	Qty.
7042	1
7043	1

7285	3
------	---

7288	1
7290	1

7287	6
------	---

7291	1
7293	1

7286	2
------	---

7298	7
------	---

EN In case that you purchased an extension kit, please select at this step on which side of the patio cover you wish to install it and continue according to the following described steps.

DE Falls Sie ein Erweiterungsset für das Produkt erworben haben, dann wählen Sie in diesem Schritt bitte aus auf welcher Seite der Patio – Überdachung Sie eses Set installieren und gehen Sie entsprechend der nachfolgenden Schritte vor.

FR Dans le cas où vous avez acheté un kit d'extension, sélectionner s'il vous plaît à cette étape, quelle côté du couvre Patio vous souhaitez l'installer et continuer en suivant les étapes décrites ci-dessous.

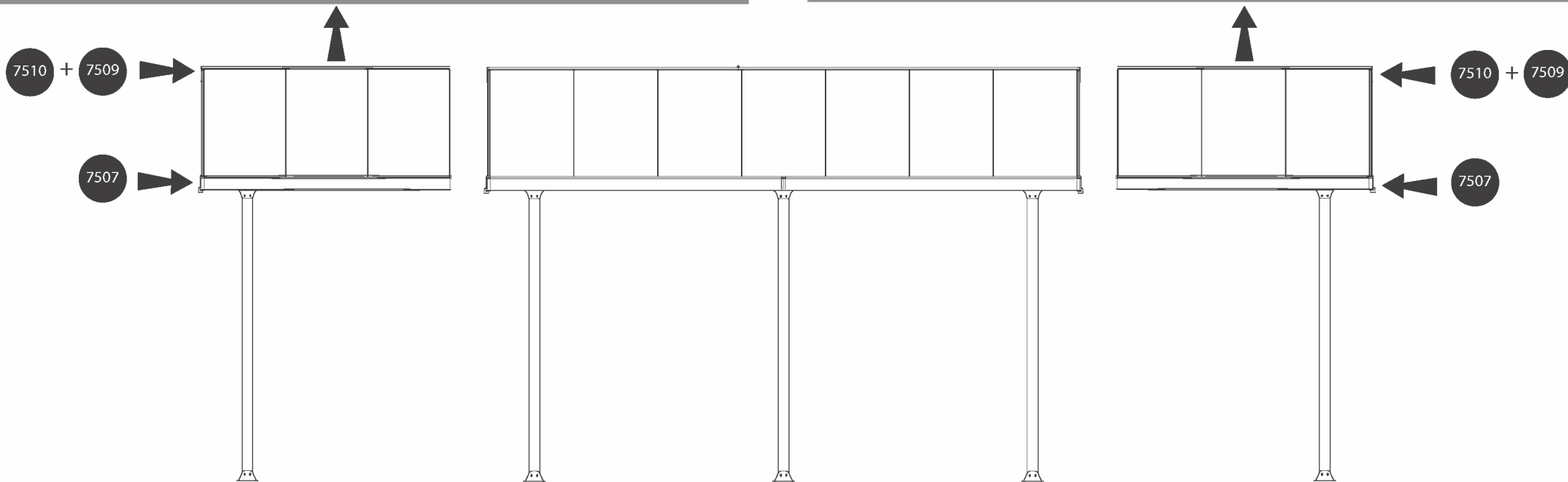
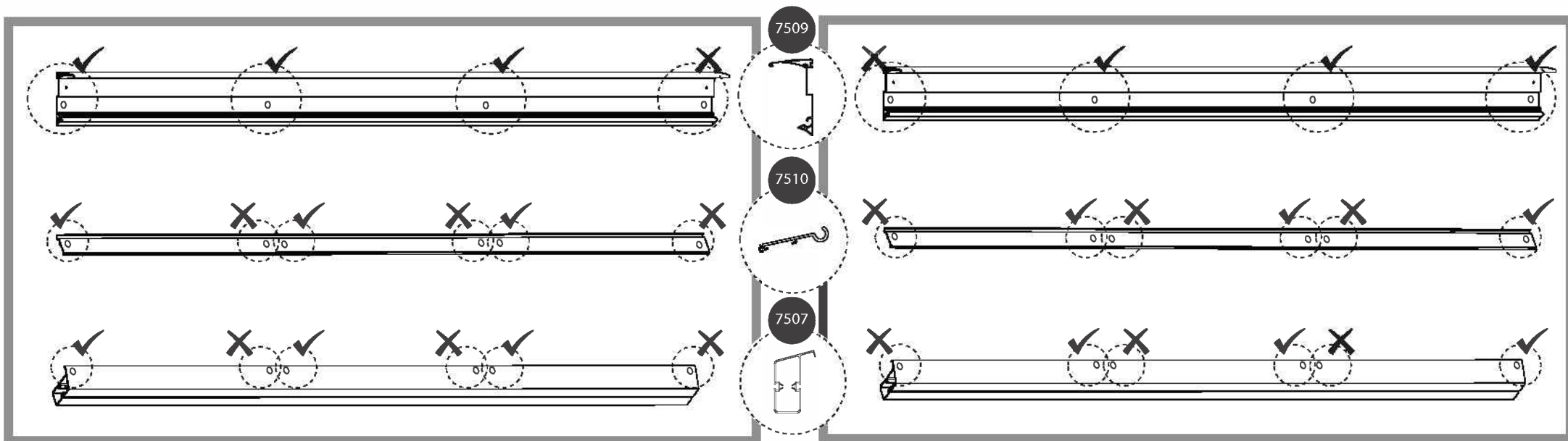

1

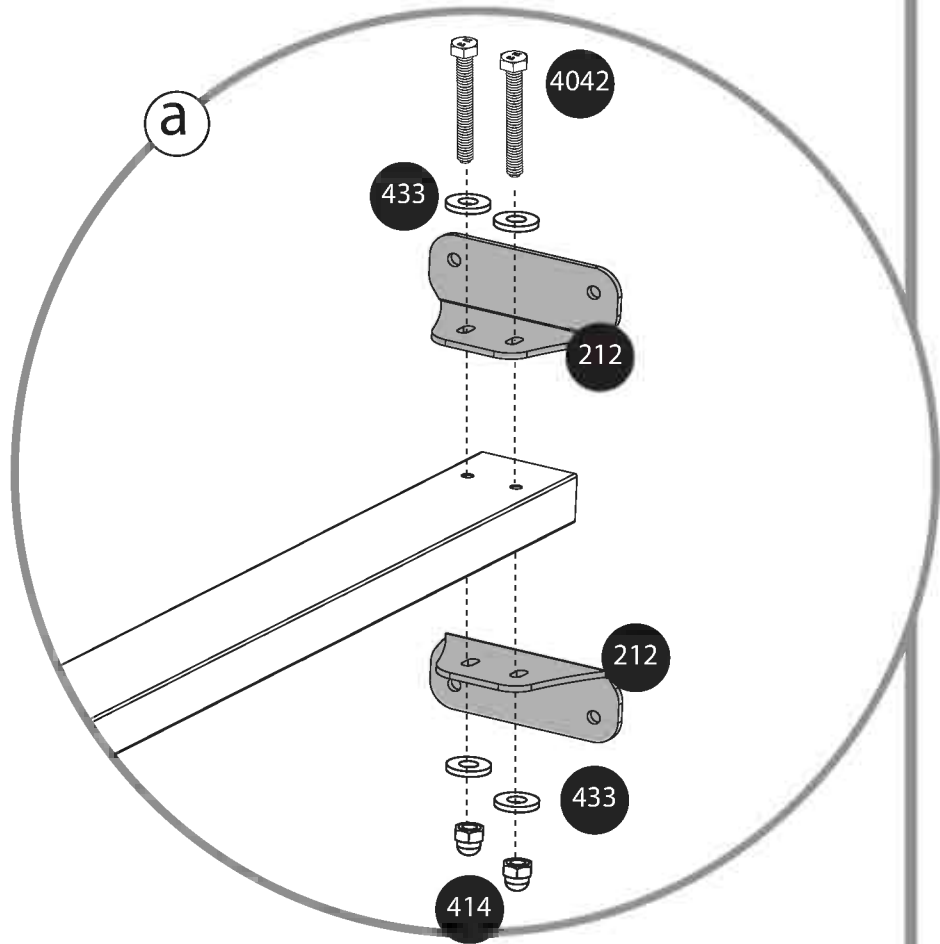
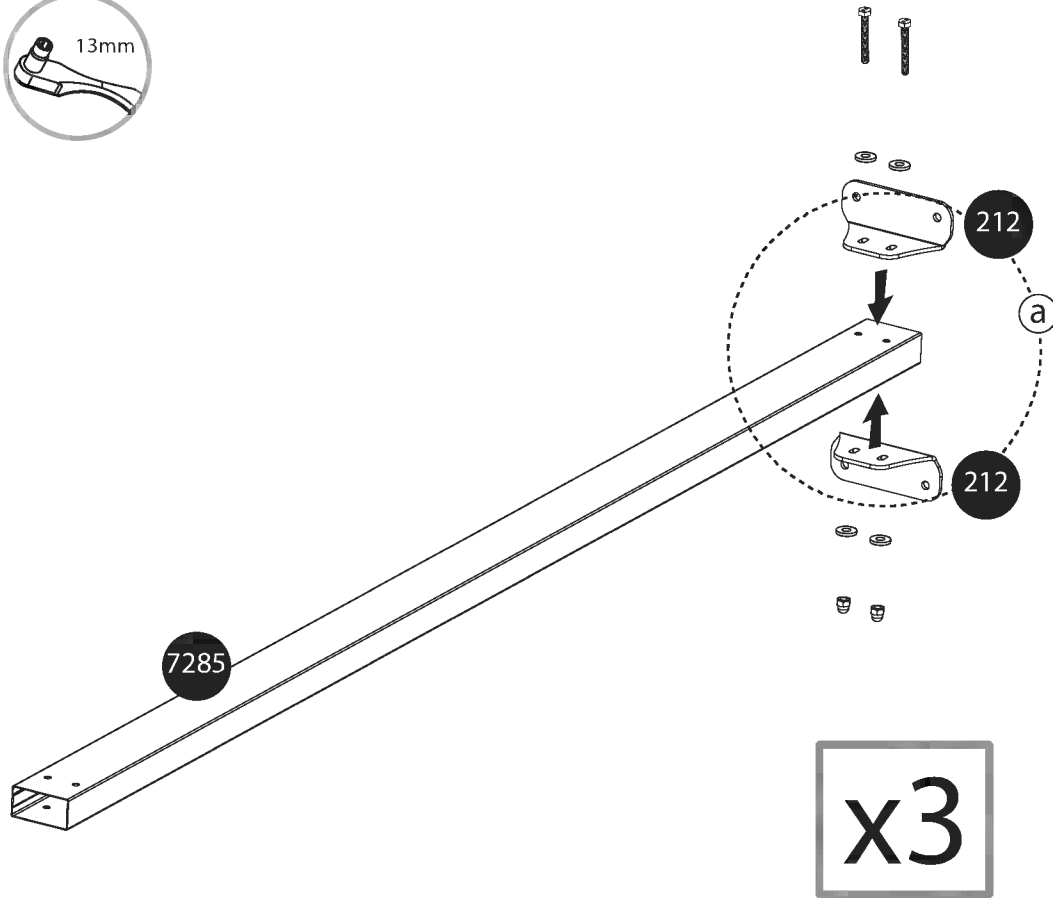
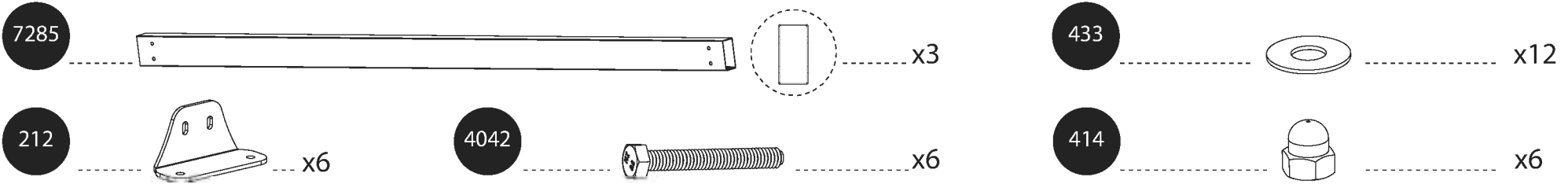

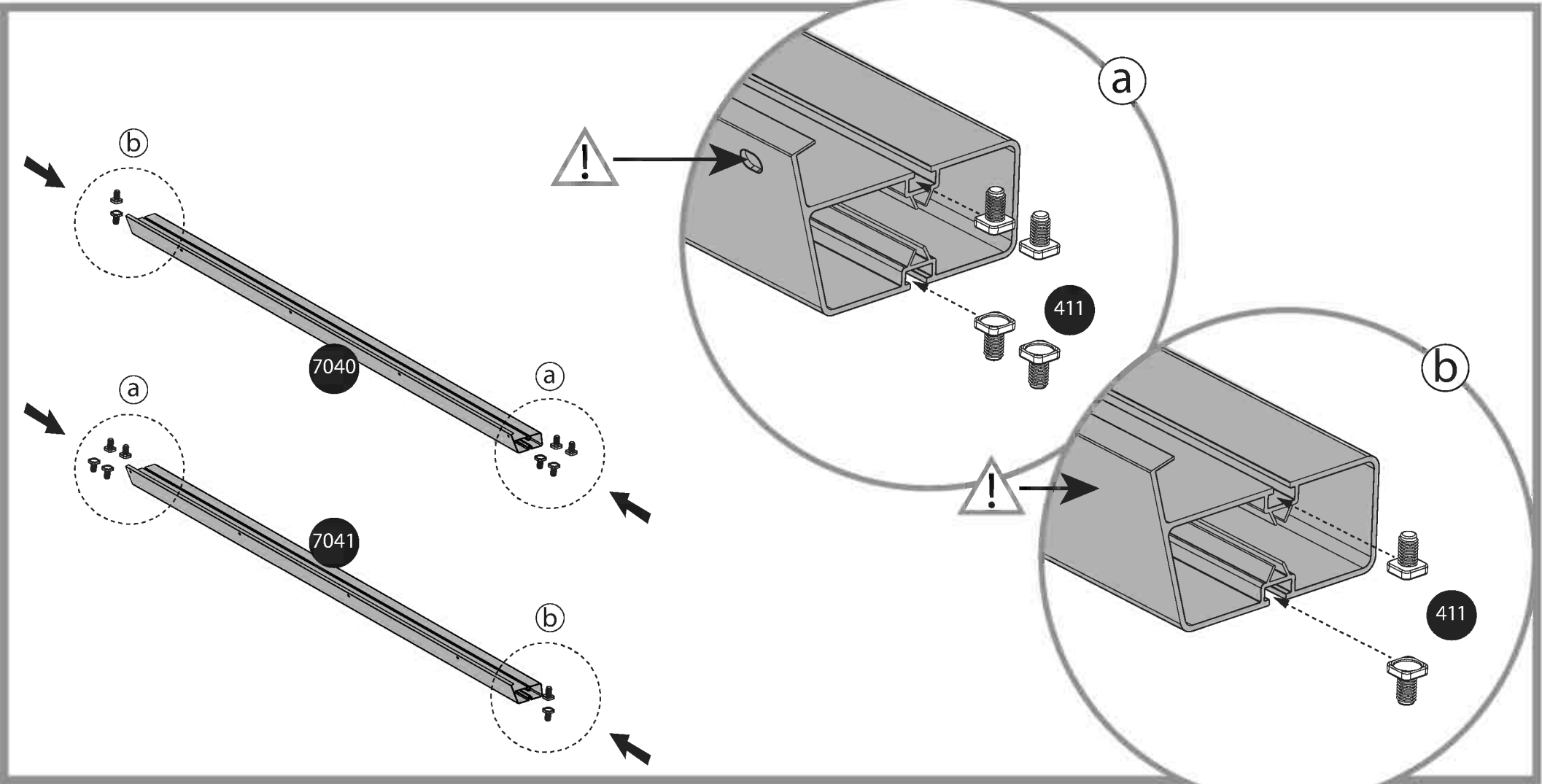
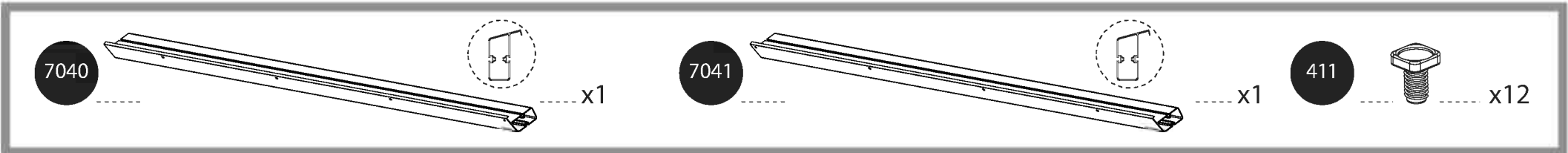

937

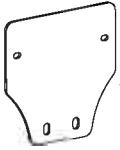

x6

466



x12

a

937



7041

b

937

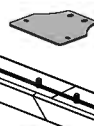

7040

a

937

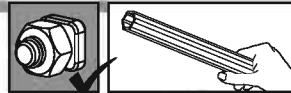

b

466

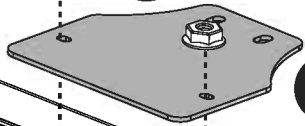

937

7041

937

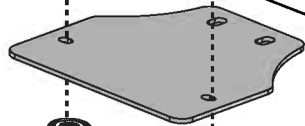

7040

466

466

a

466

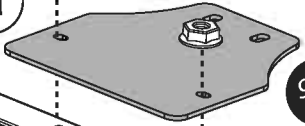

937

7040 / 7041

937

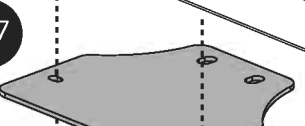

466

0 - 54cm
0 - 21.2"

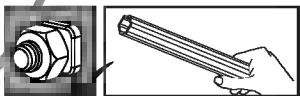

7040

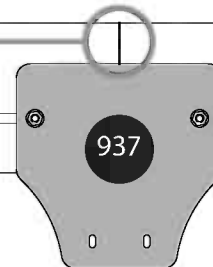

7041

4



7506



x1

447



x2

7507

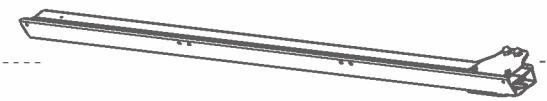

x1

7507

L

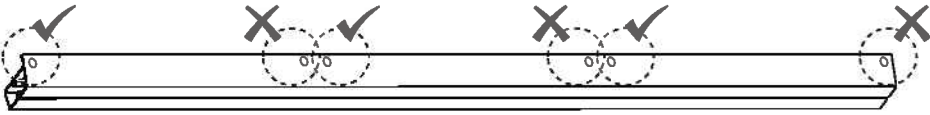

OR

7507

R

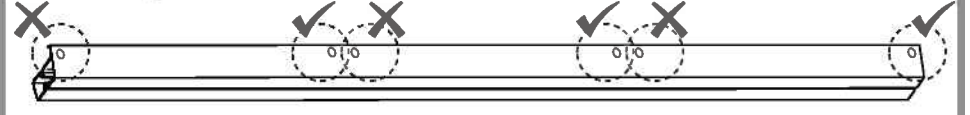

a

15cm
6"

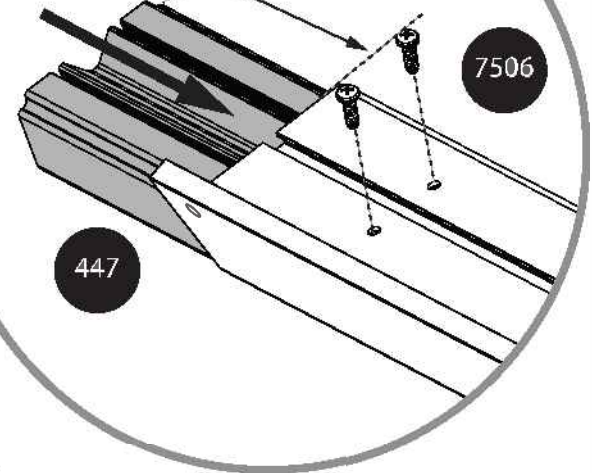

447

7506

7506

a

7507

937

5

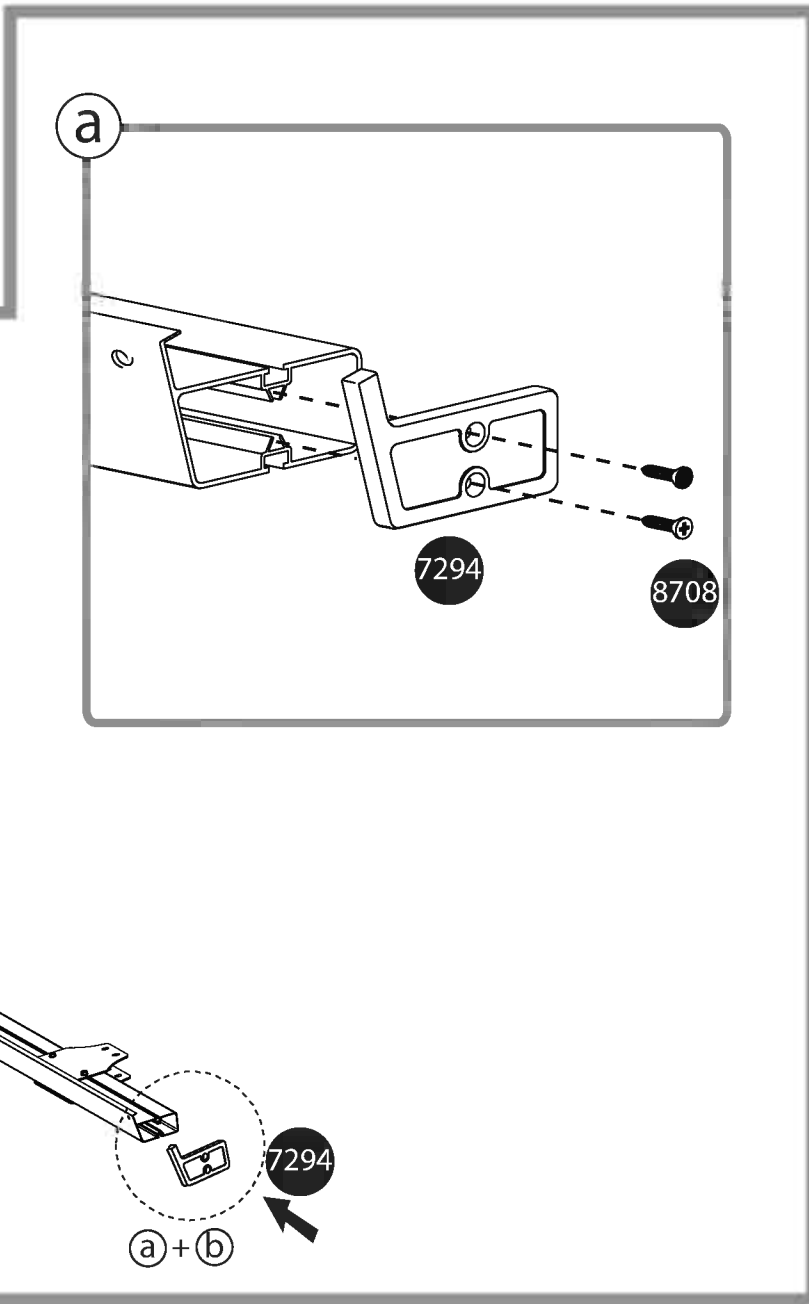
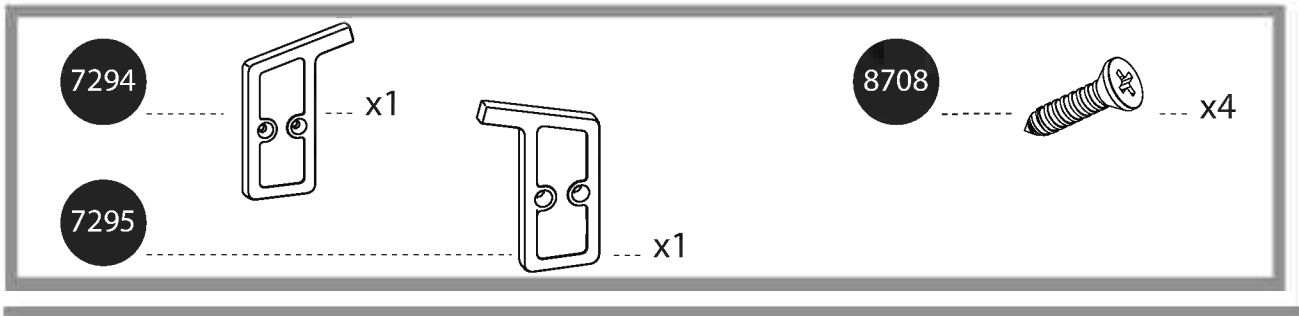

6

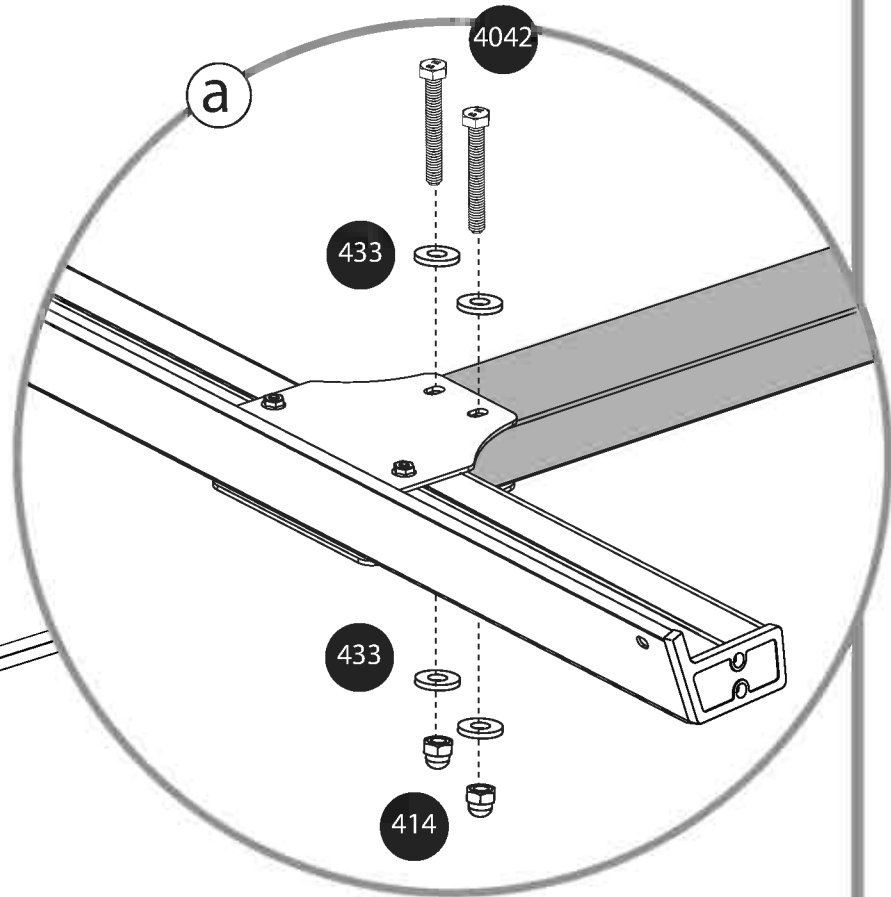
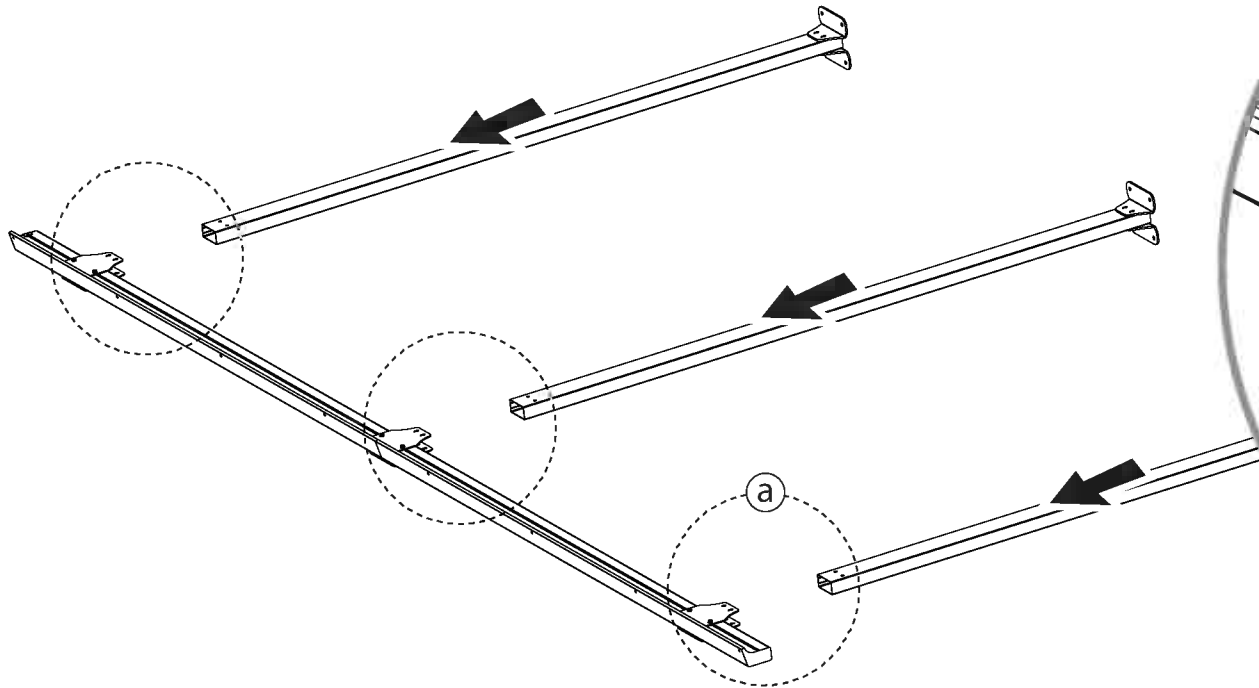
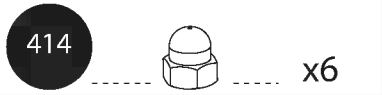
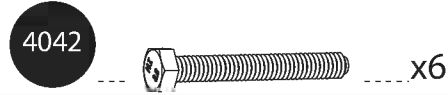
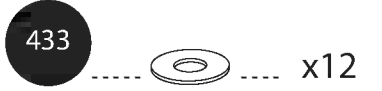

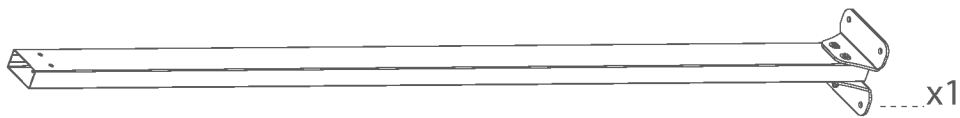

4042



433



414

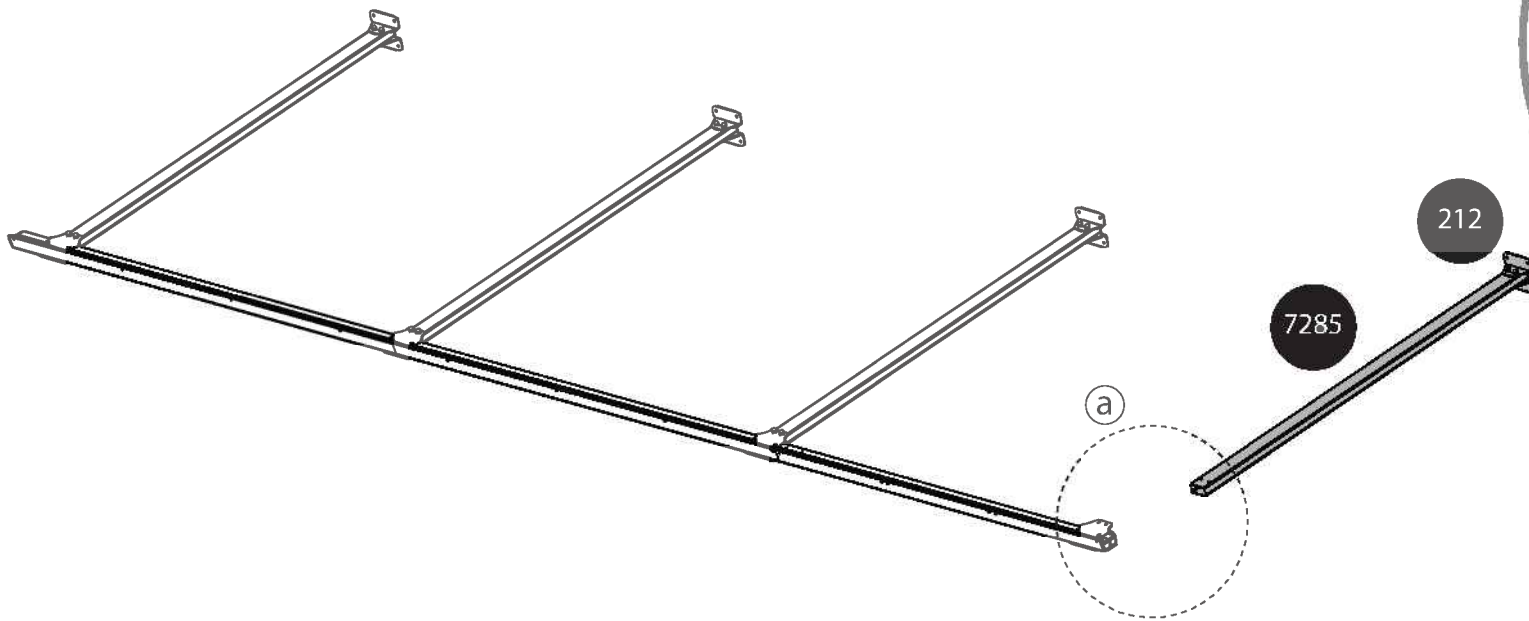

a

4042

433

433

414

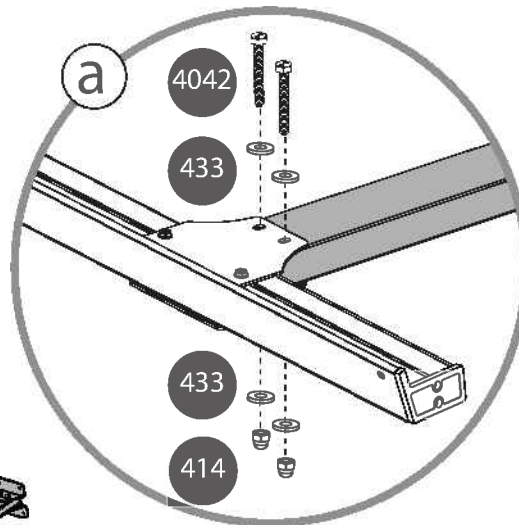

7039

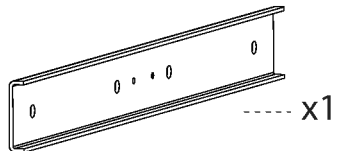

x1

7029

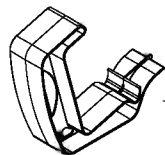

x1

466



x4

411



x4

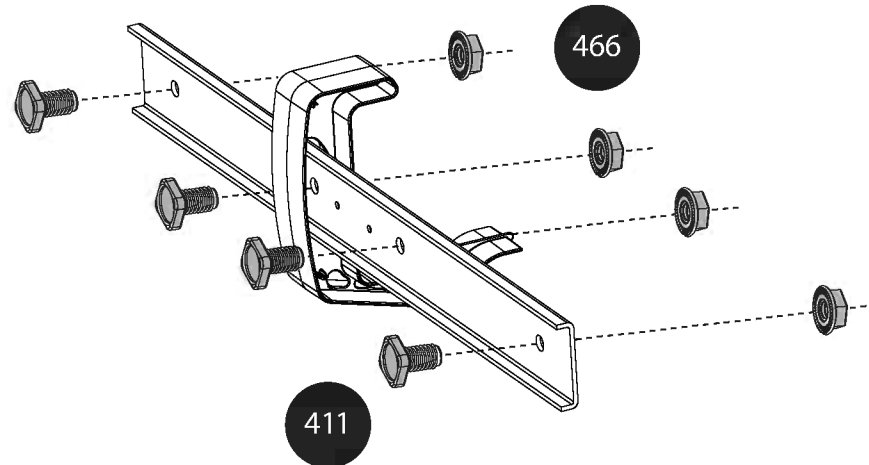
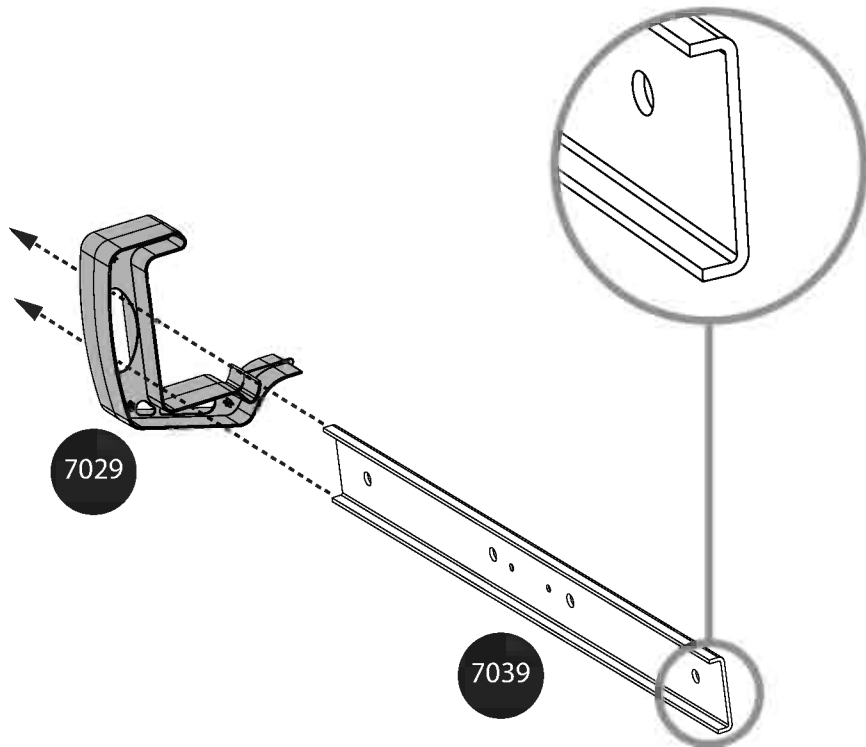

7042



7043

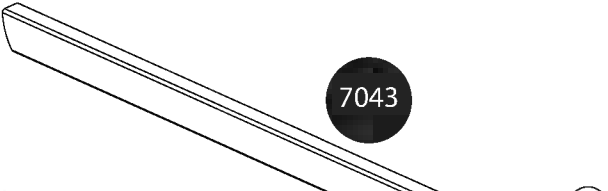
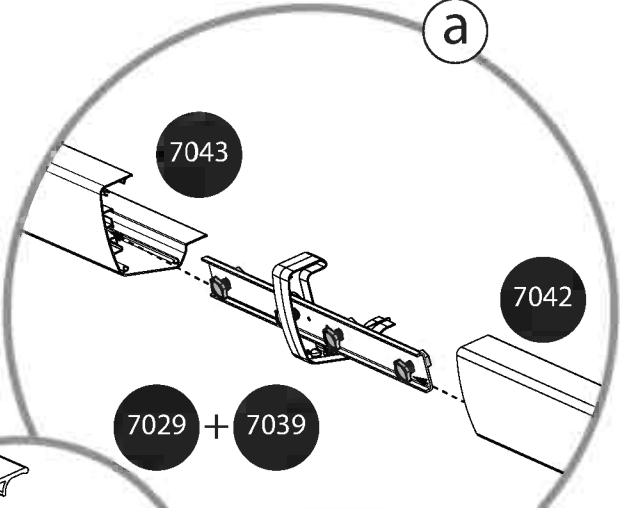
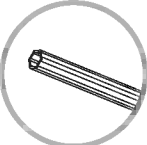
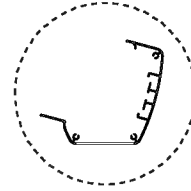
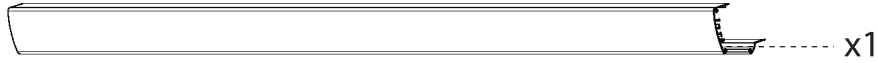

Option:
CAULK / SILICON

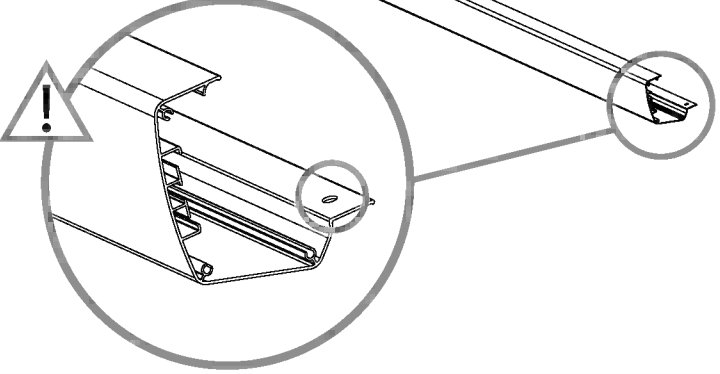
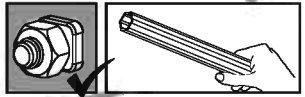
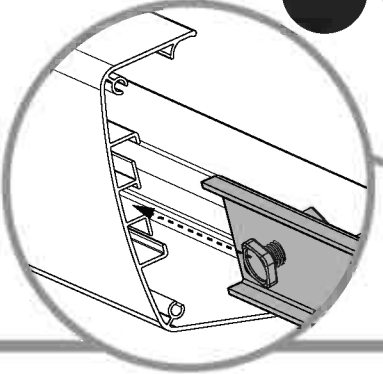
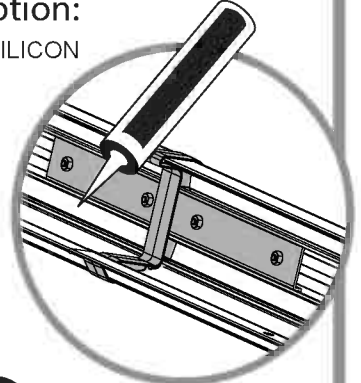

7508



x1



x1

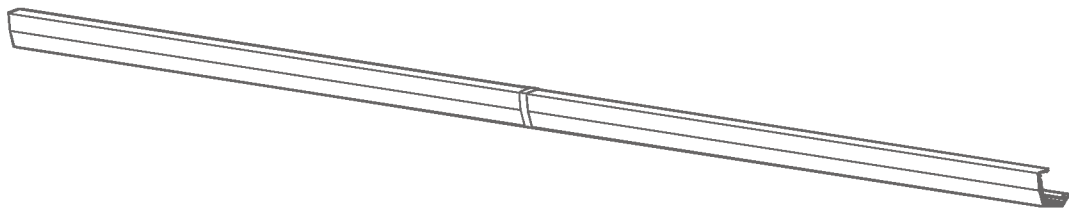

7029



7039

7508

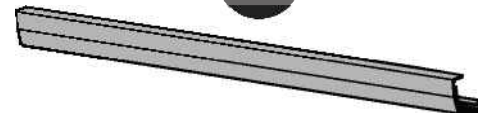

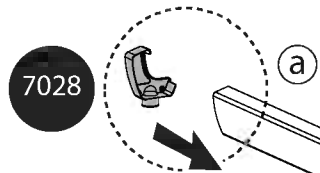
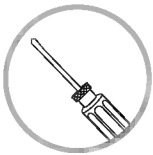
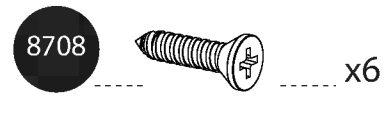
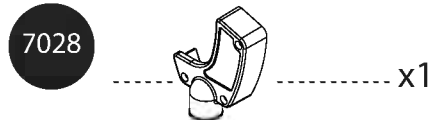
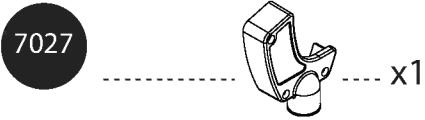

7043

7042

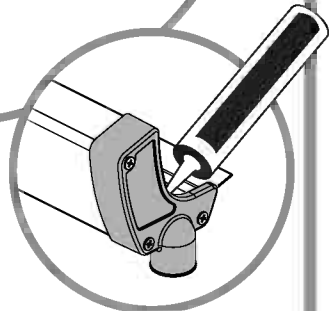
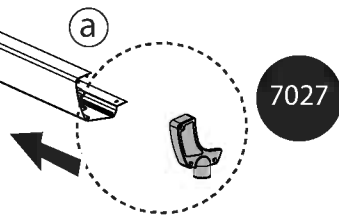
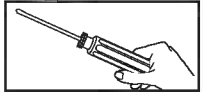
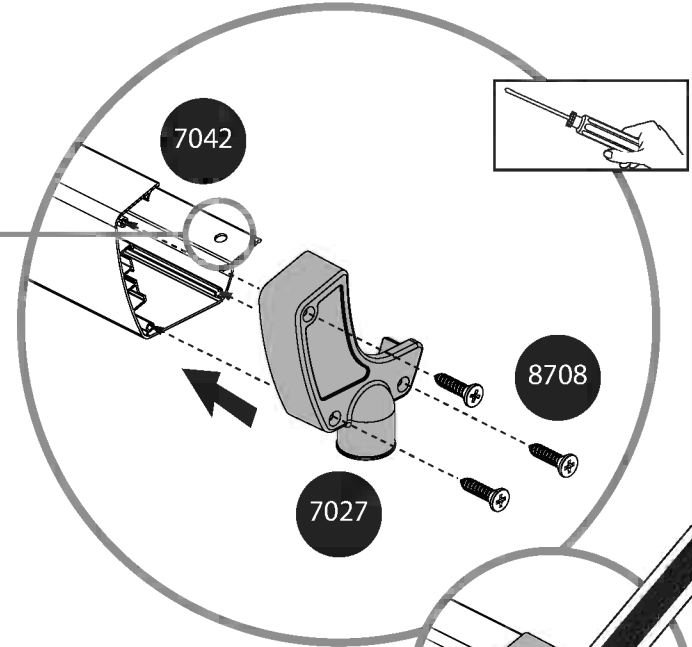

Option:
CAULK / SILICON

7290

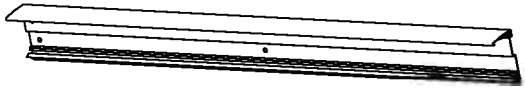

x1

4010

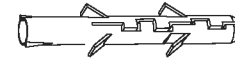

x2

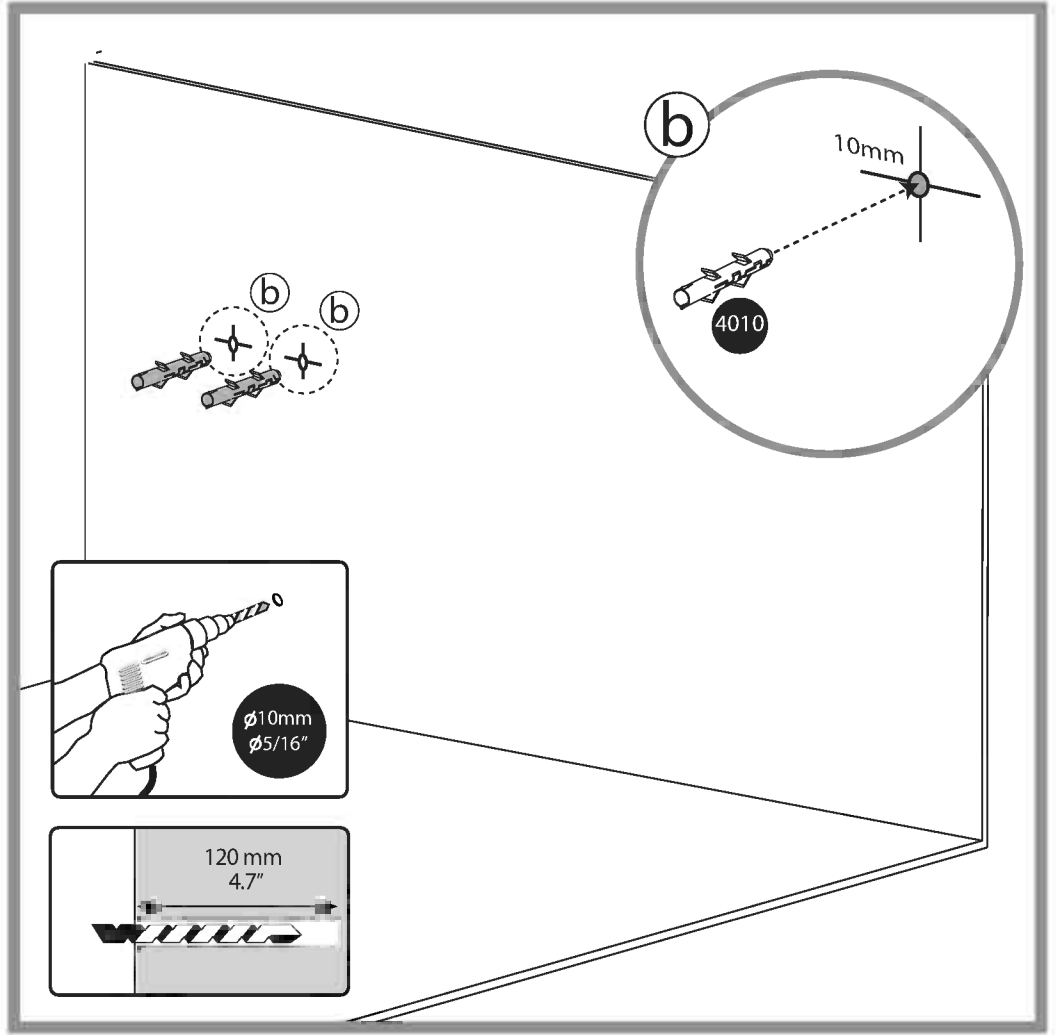
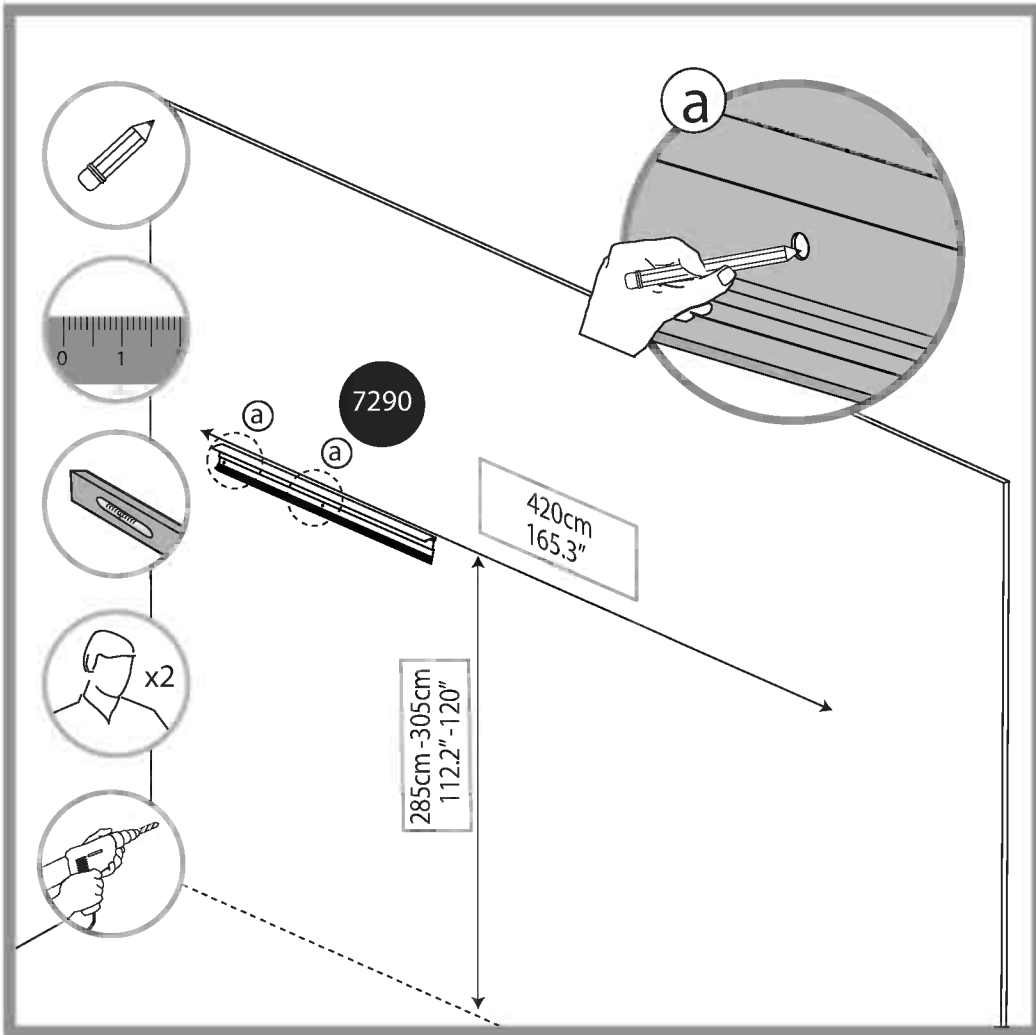

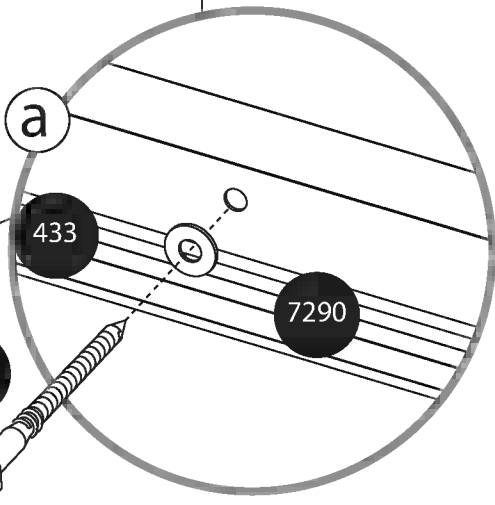
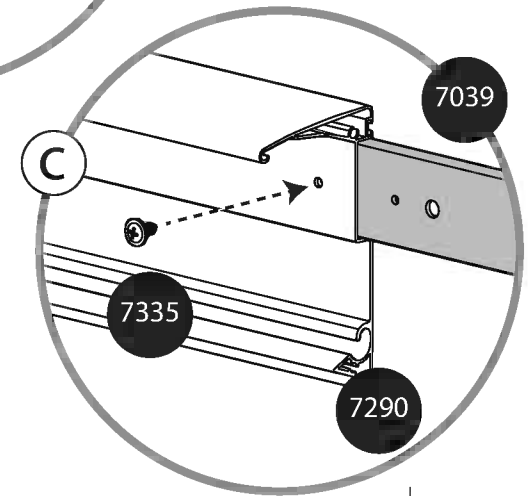
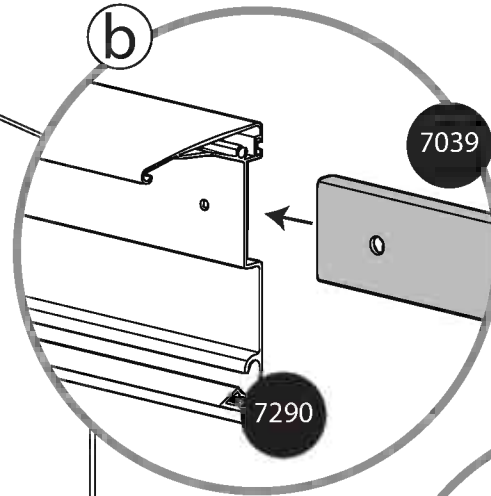
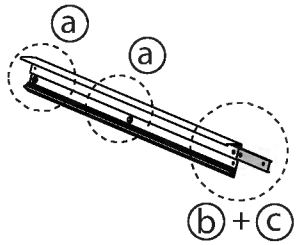
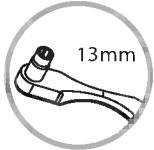
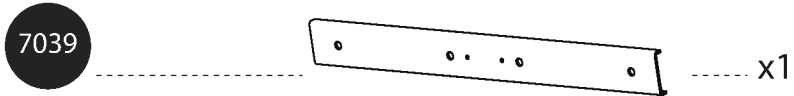
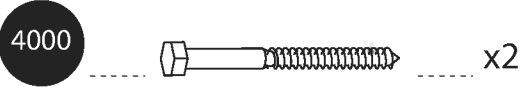

7288



x1

4010

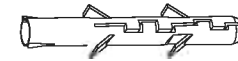

x6

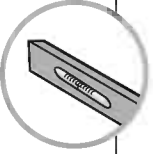
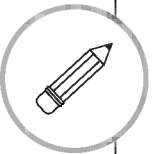
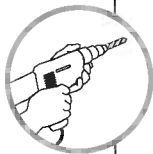

7290

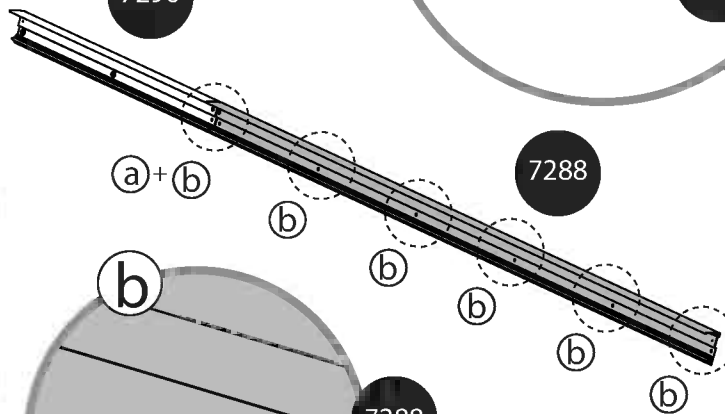

7288

7288

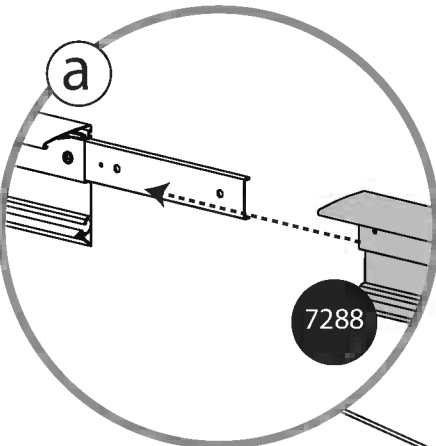

7288

C

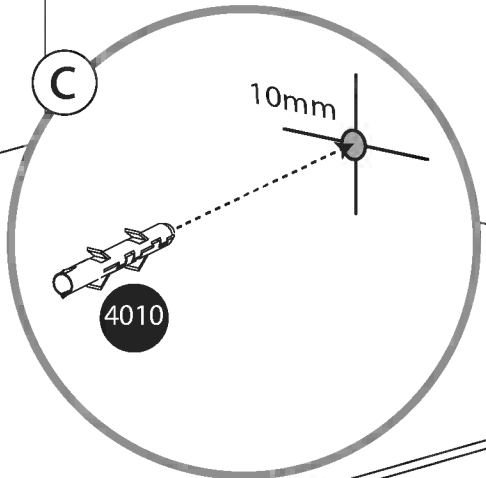
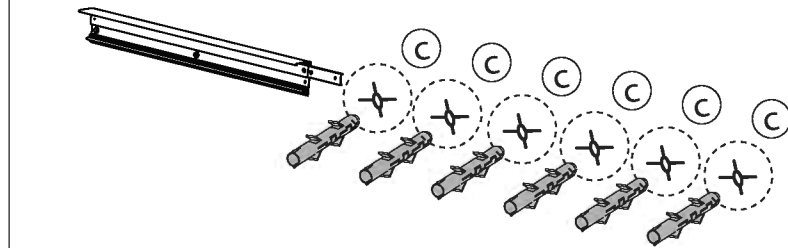

10mm

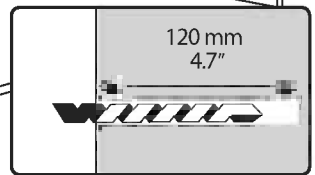
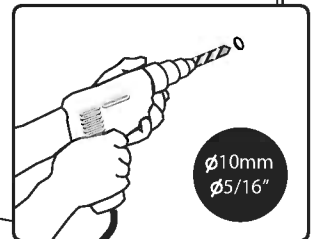

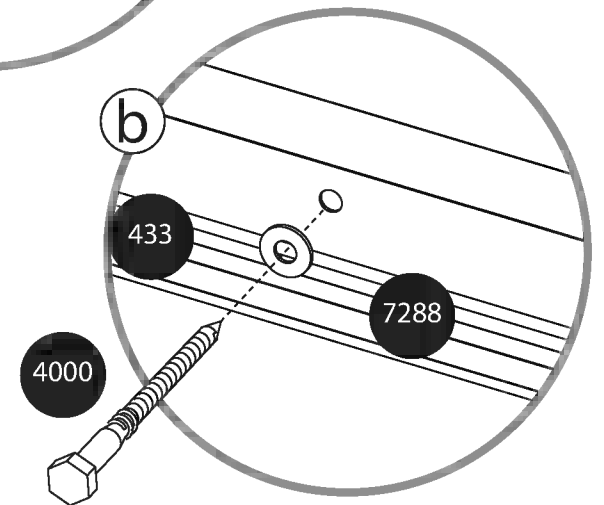
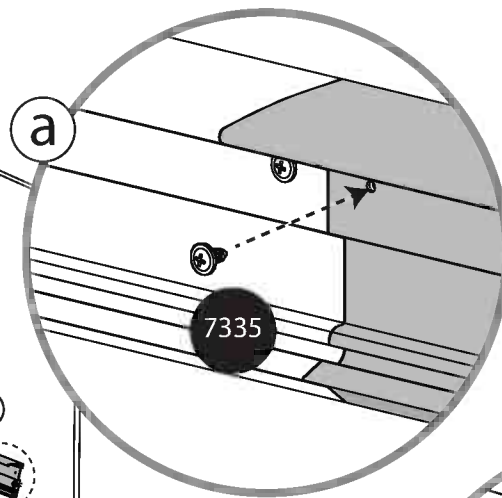
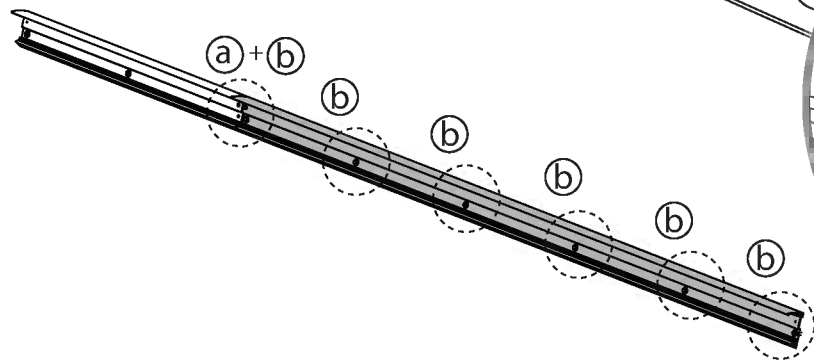
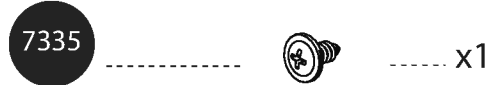

7291



x1

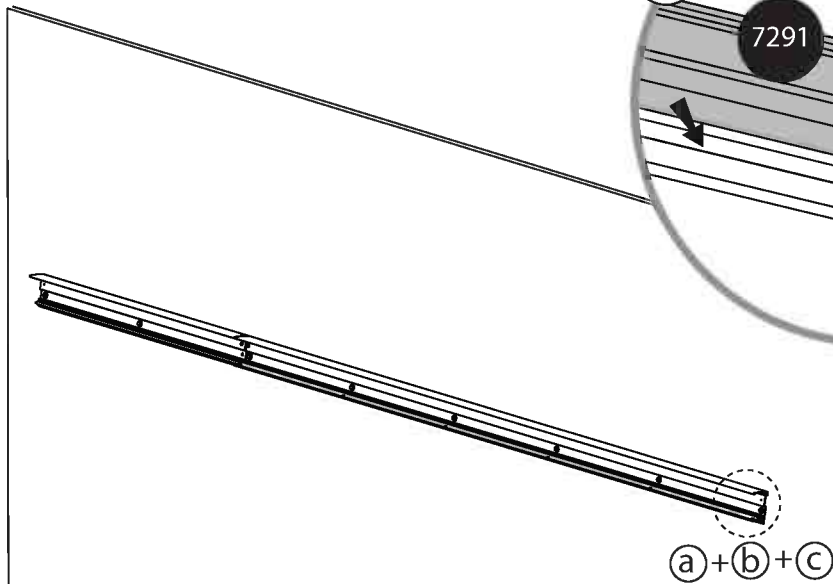
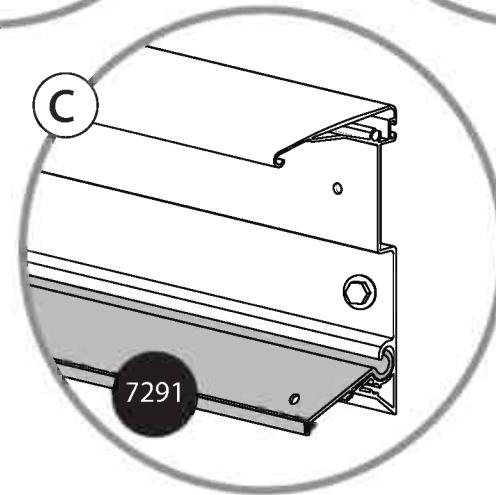
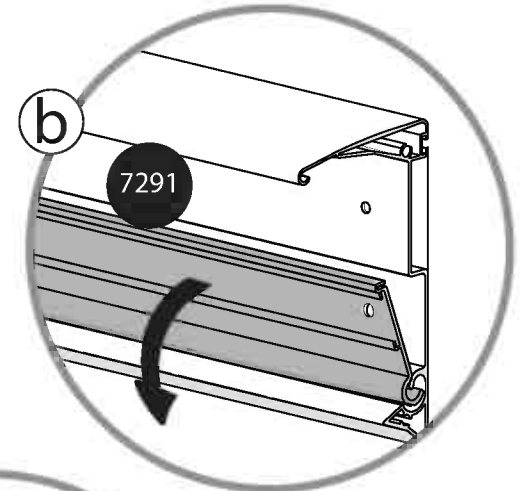
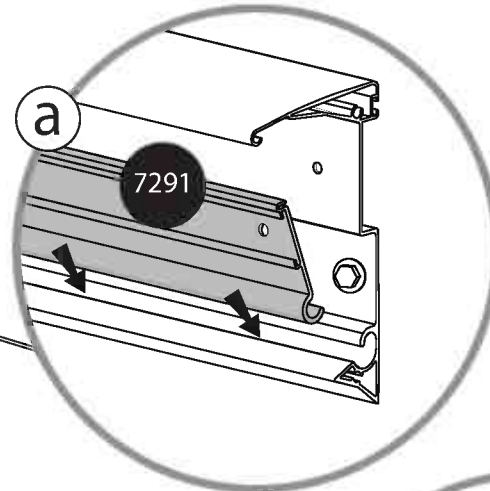

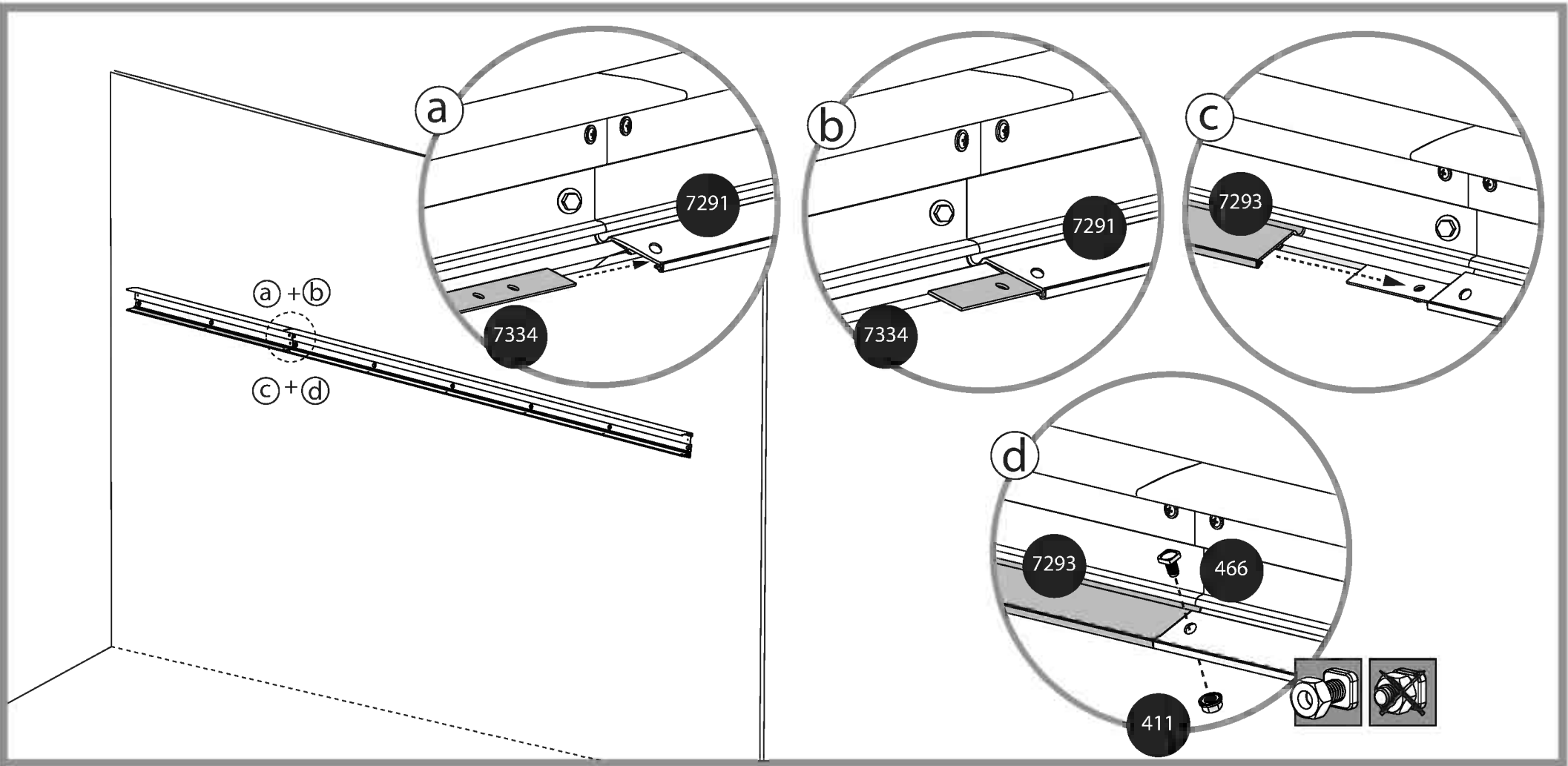
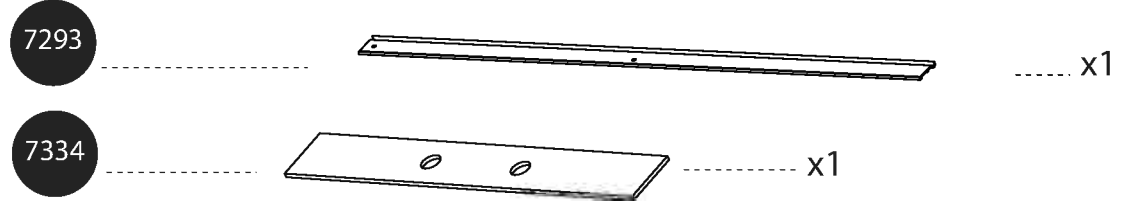
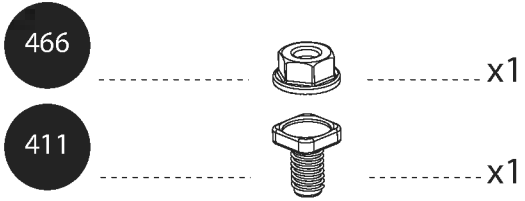

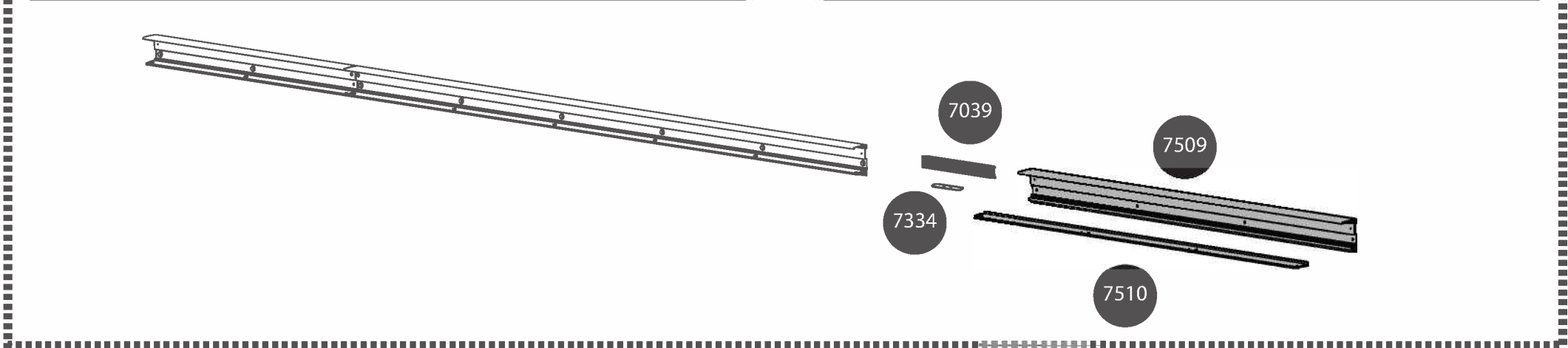
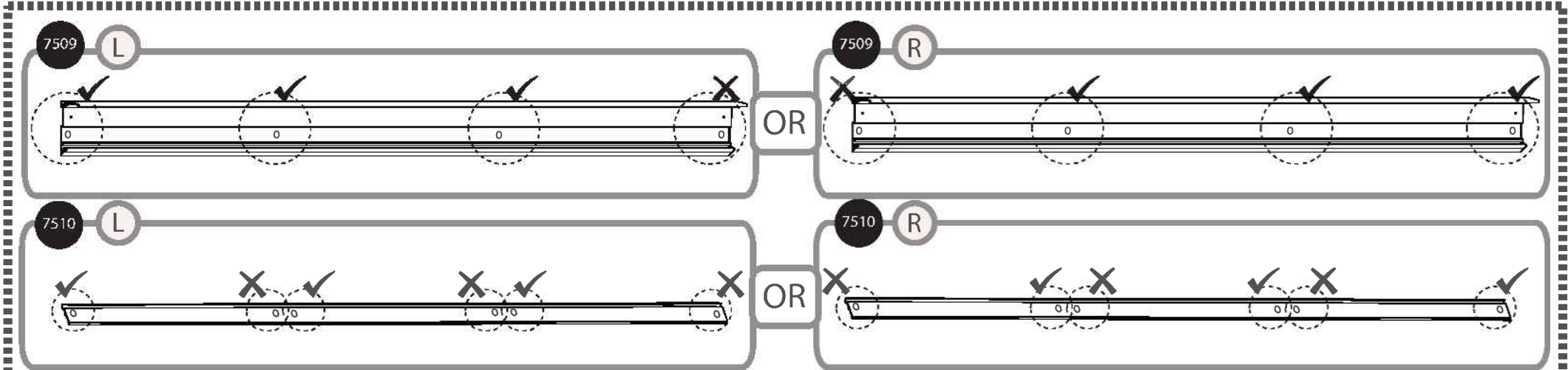
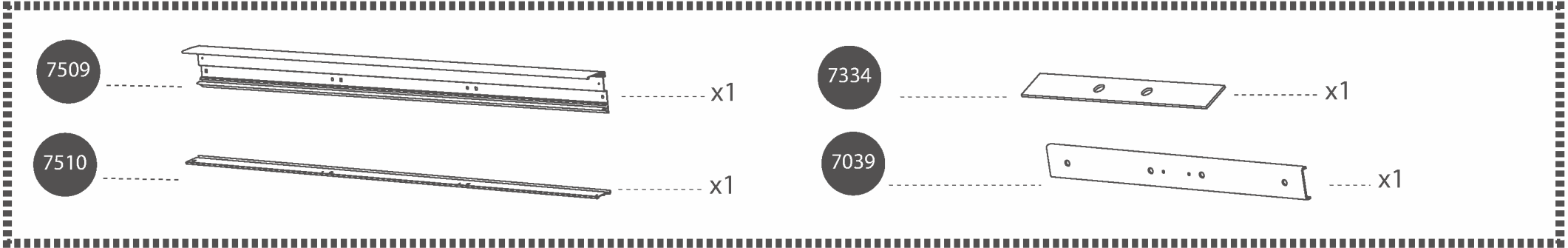

- 466 x7
- 411 x7

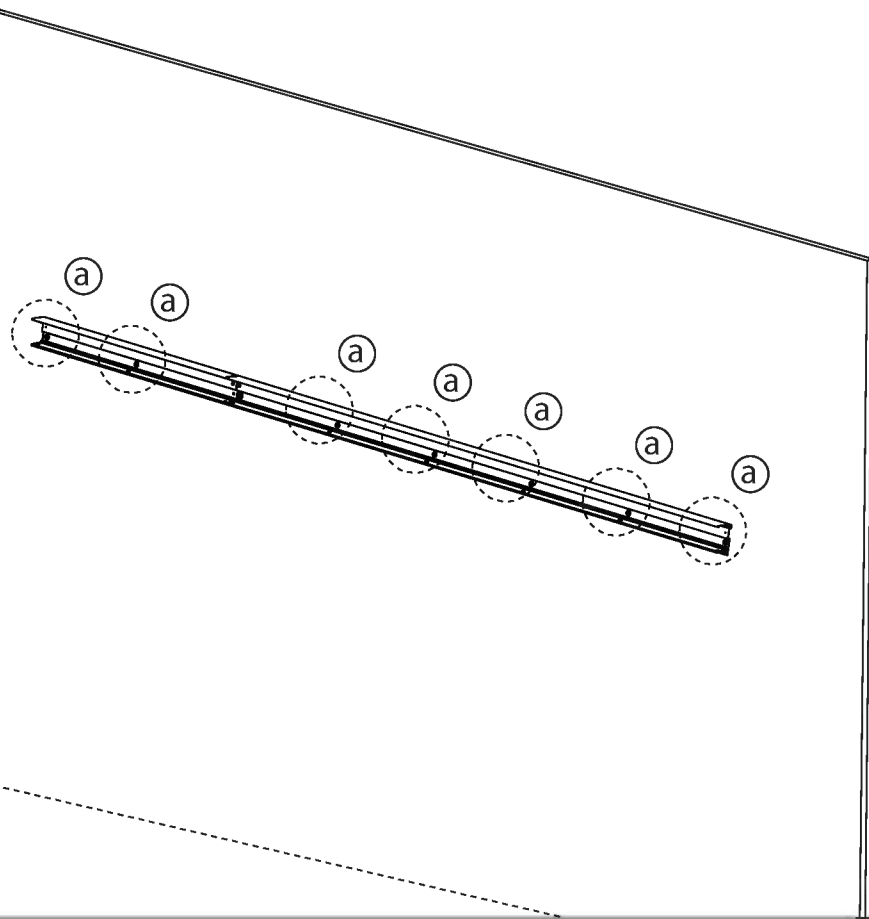
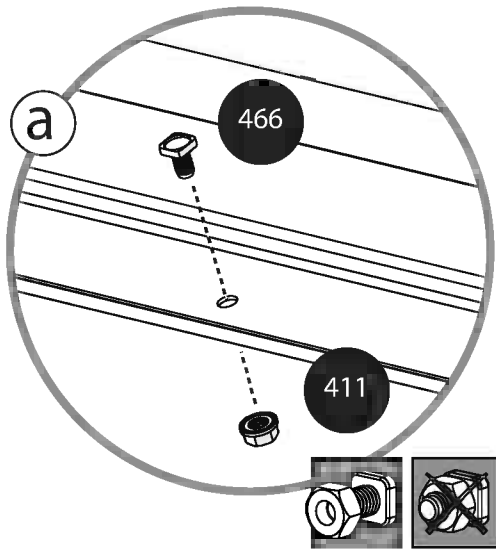

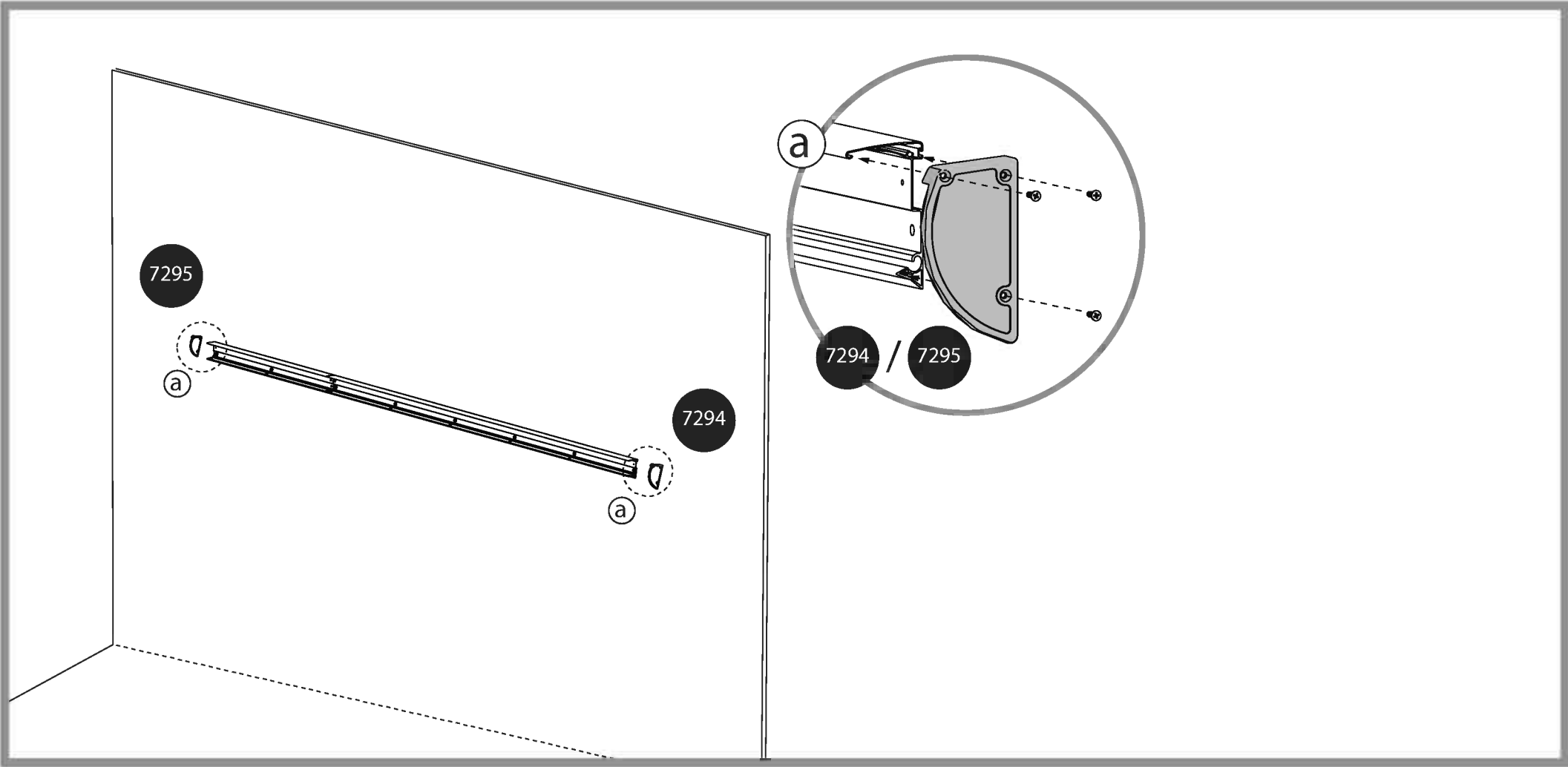
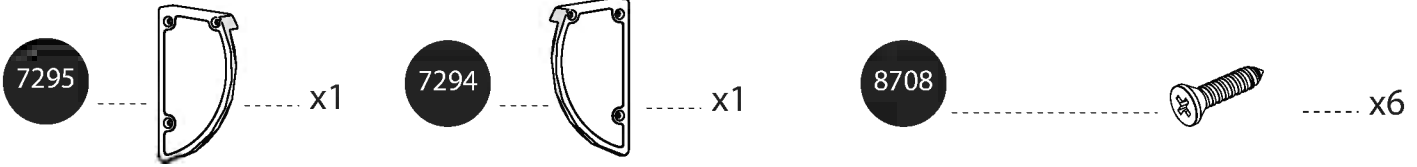

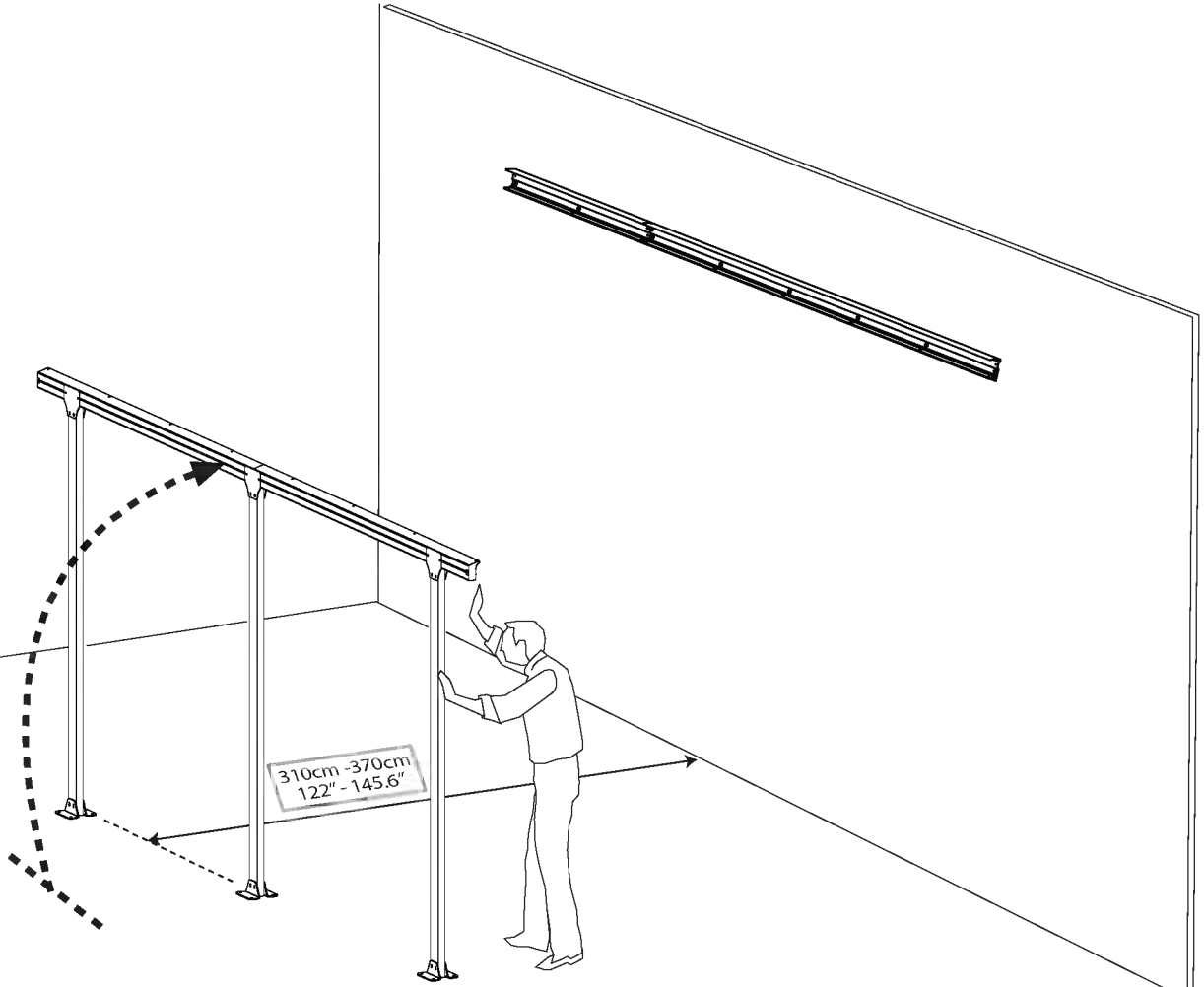

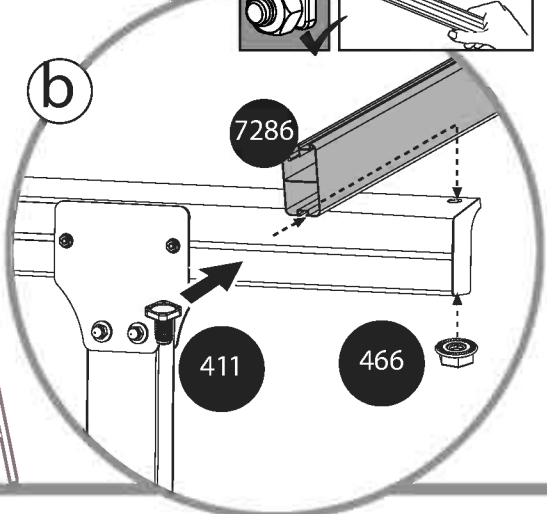
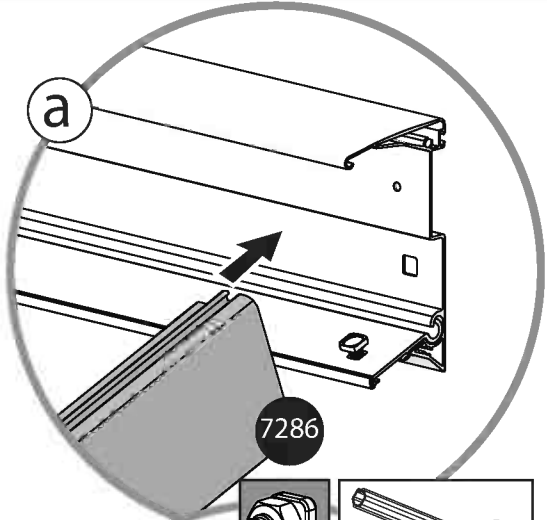
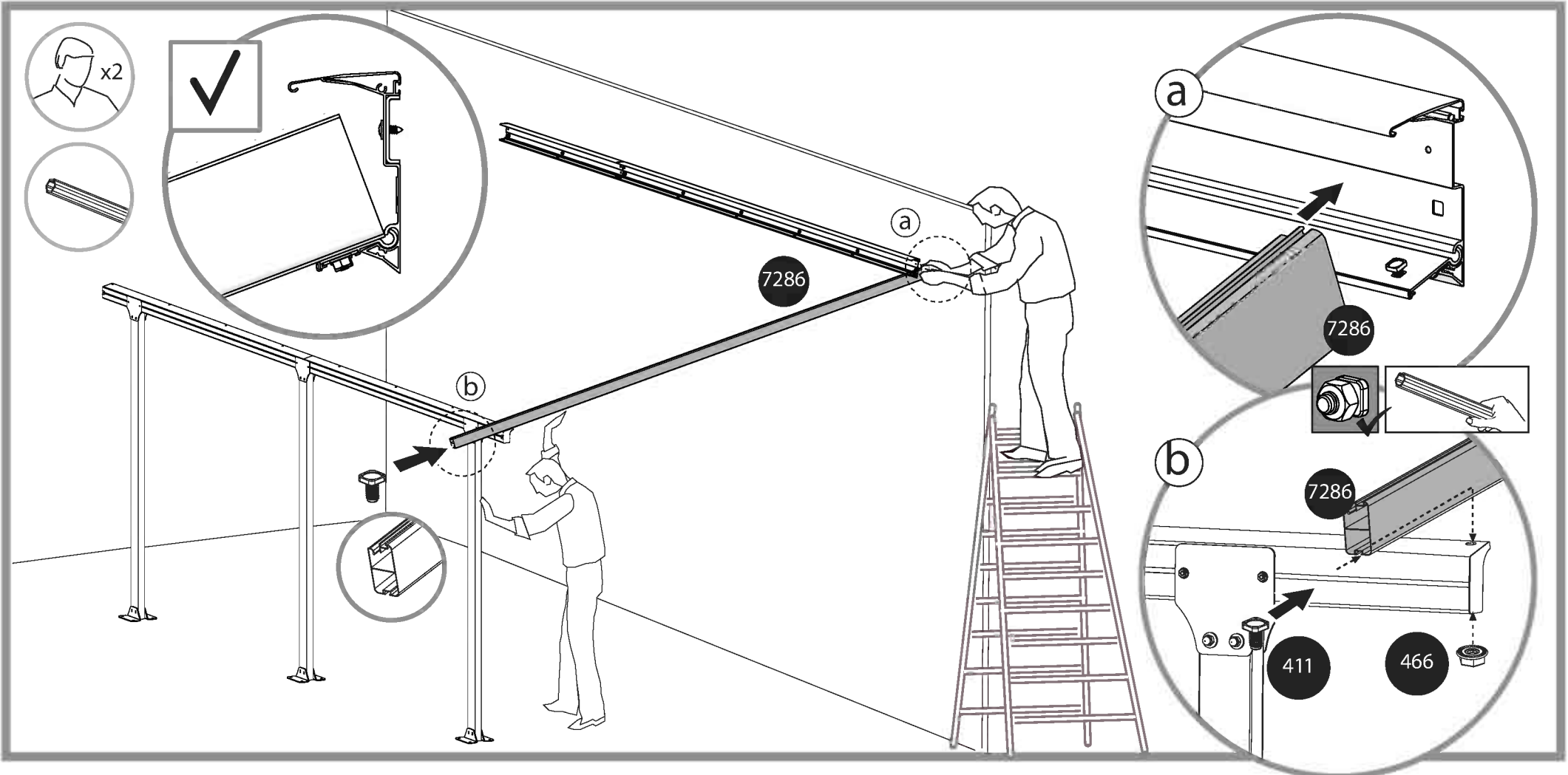
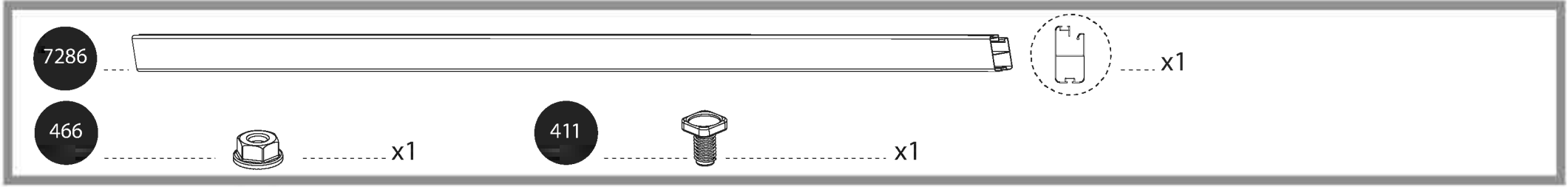

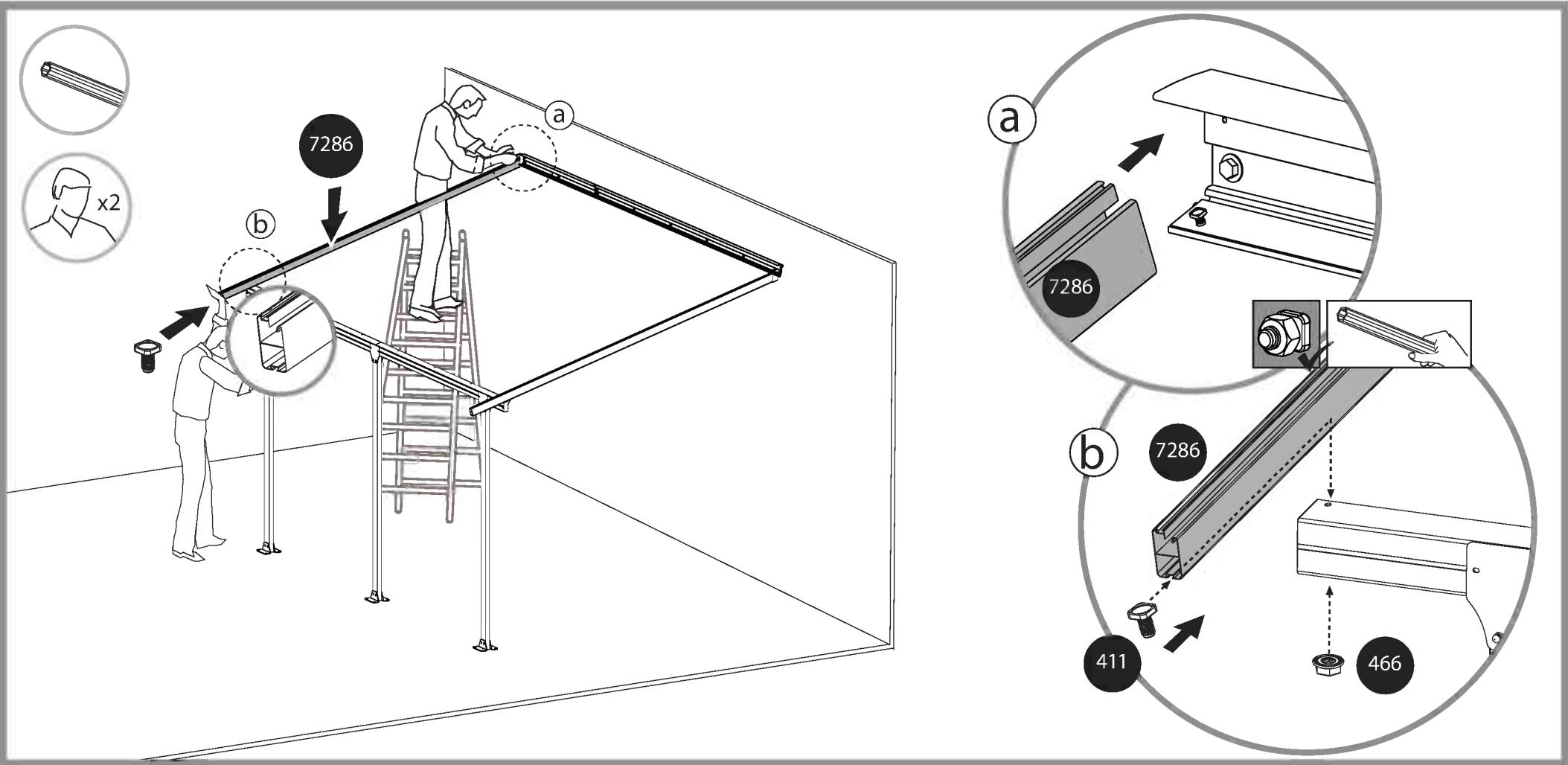
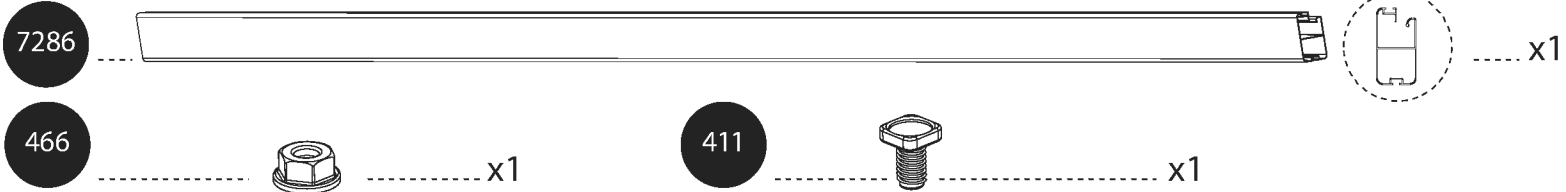

7287



x6

466



x6

411



x6

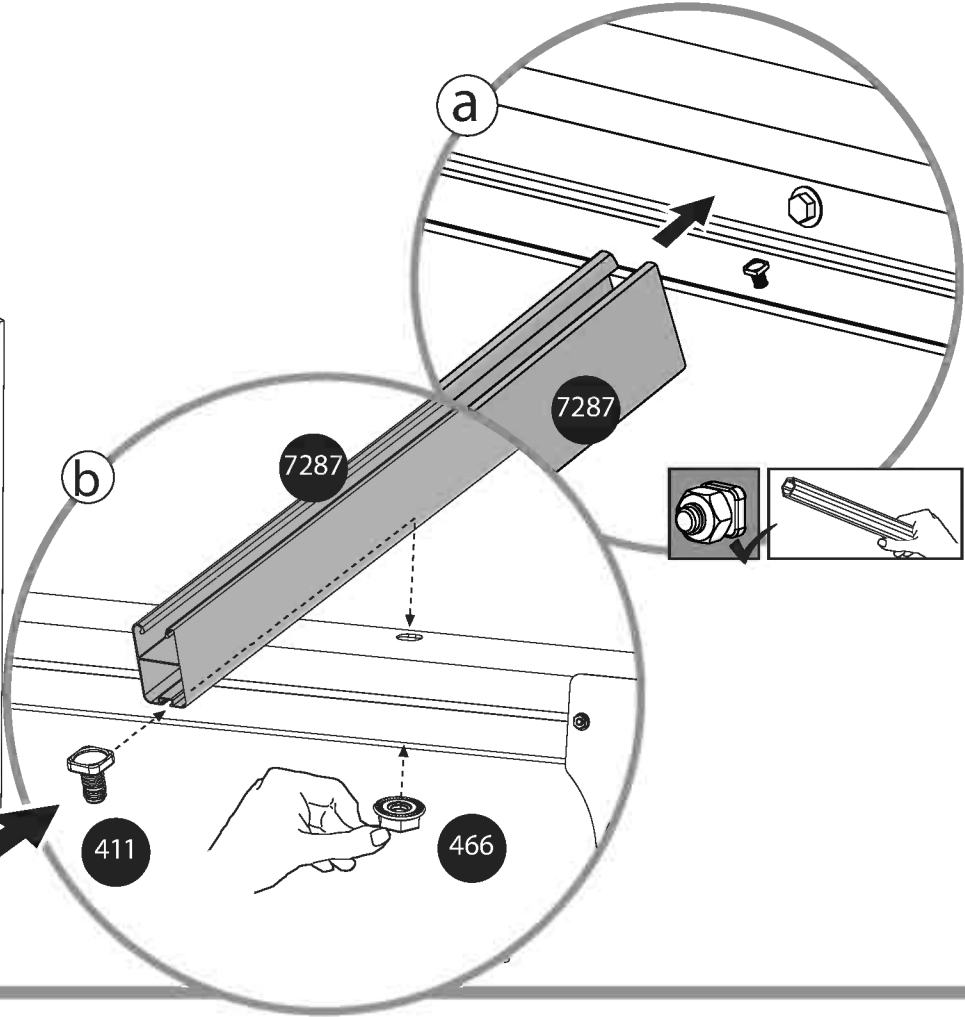
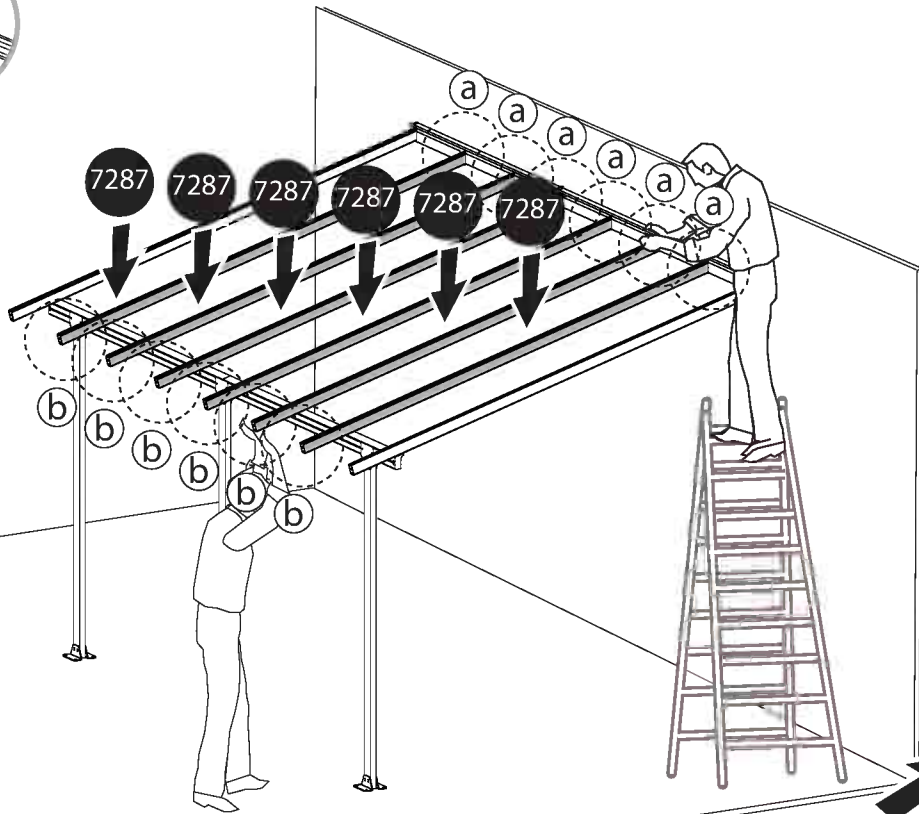
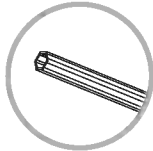

7298

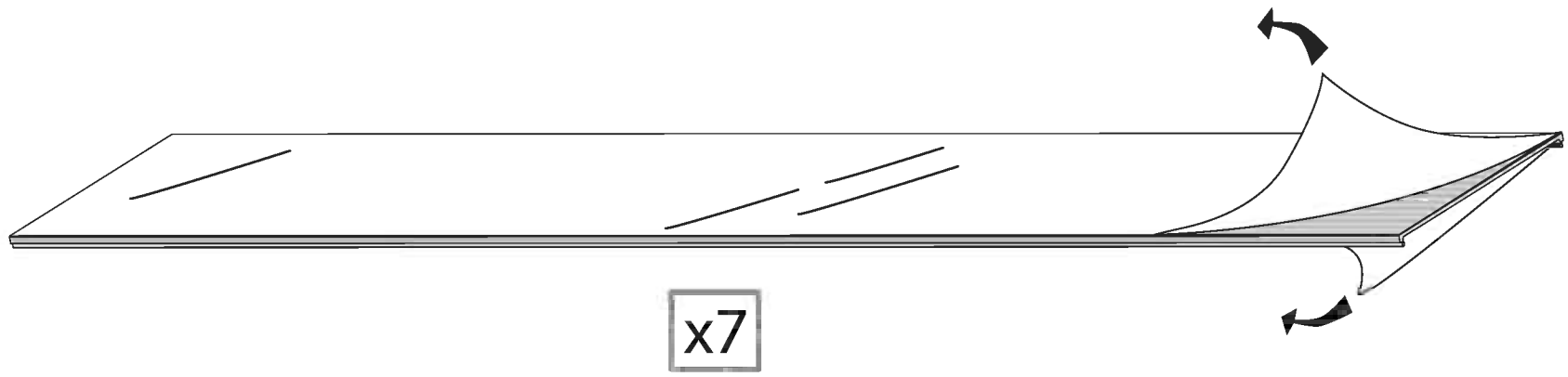

7298

x1



90°

7298

7298

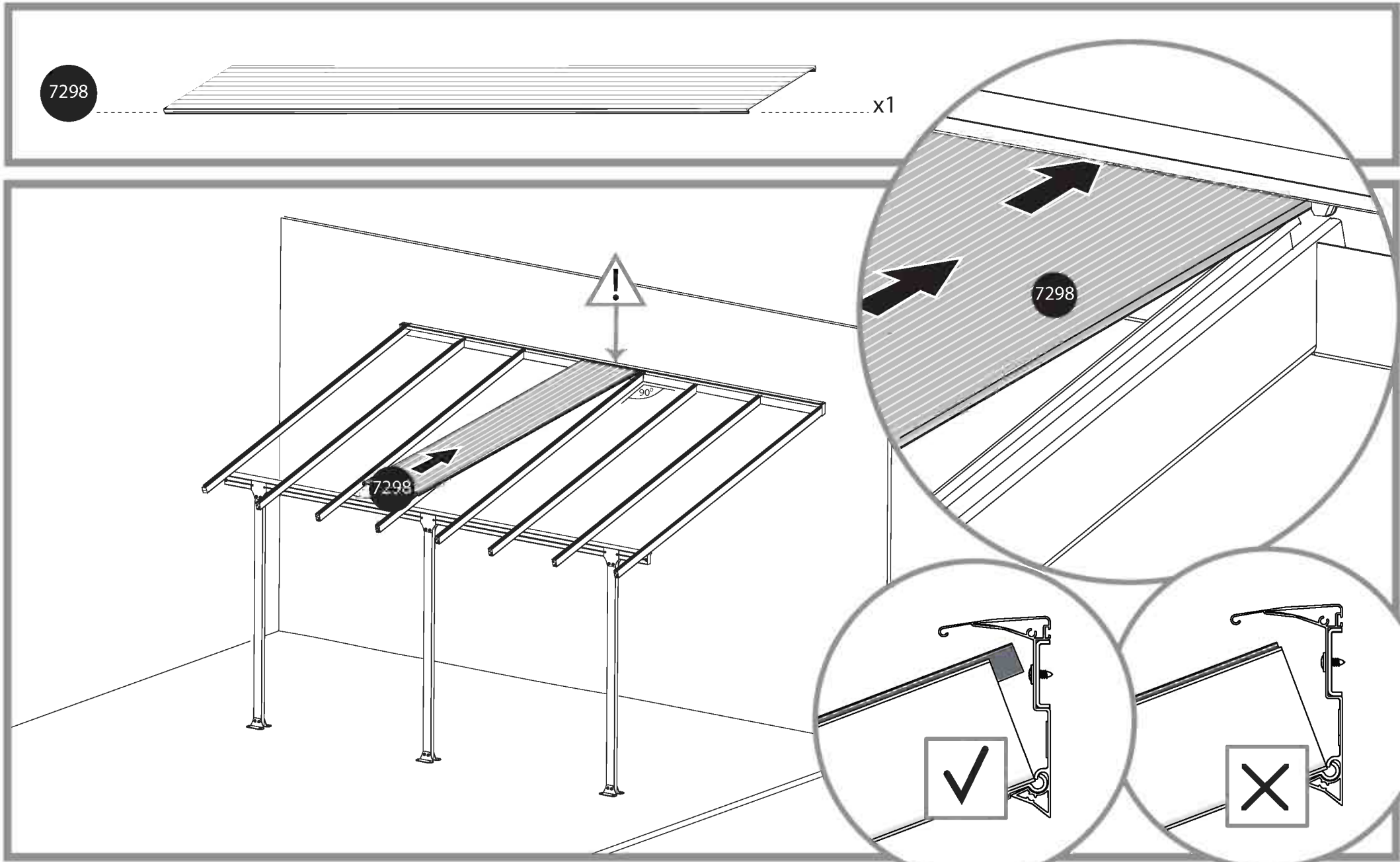

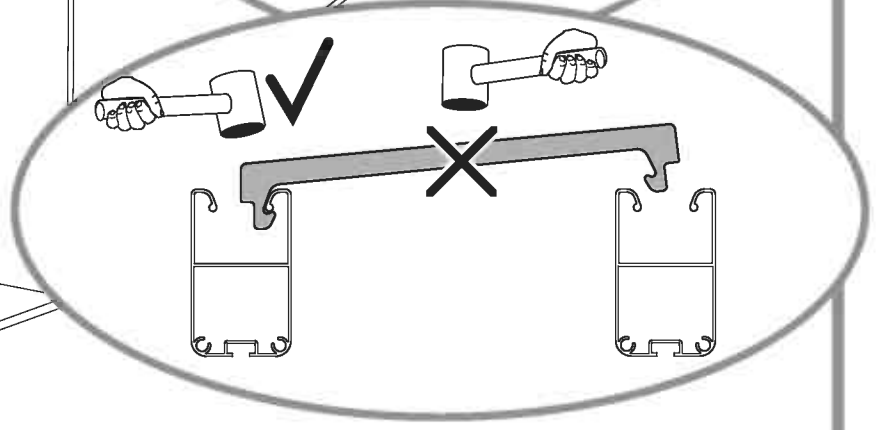
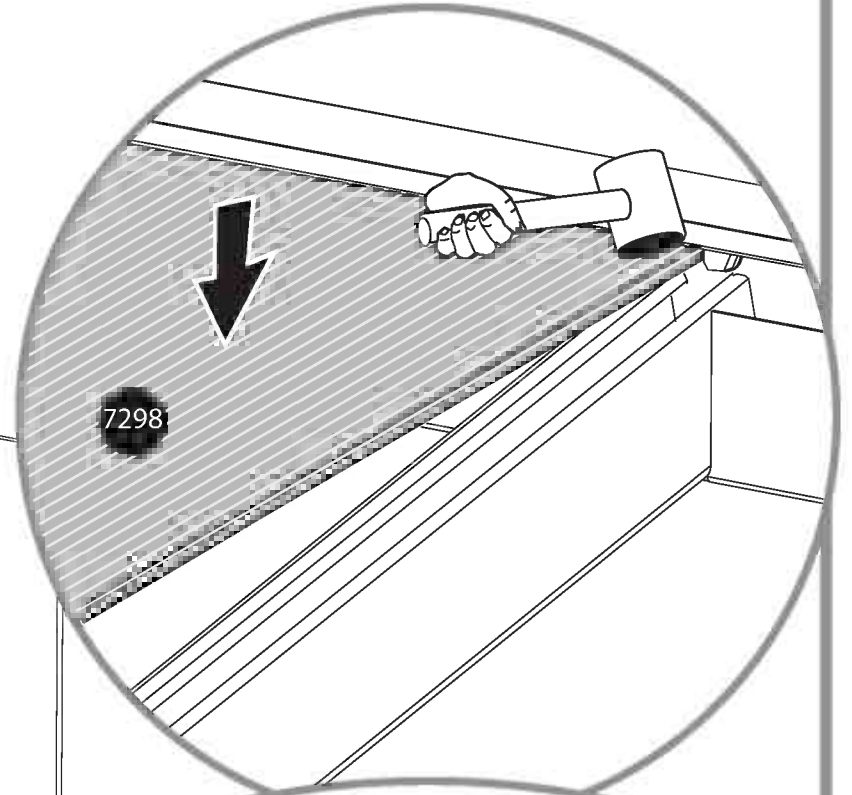
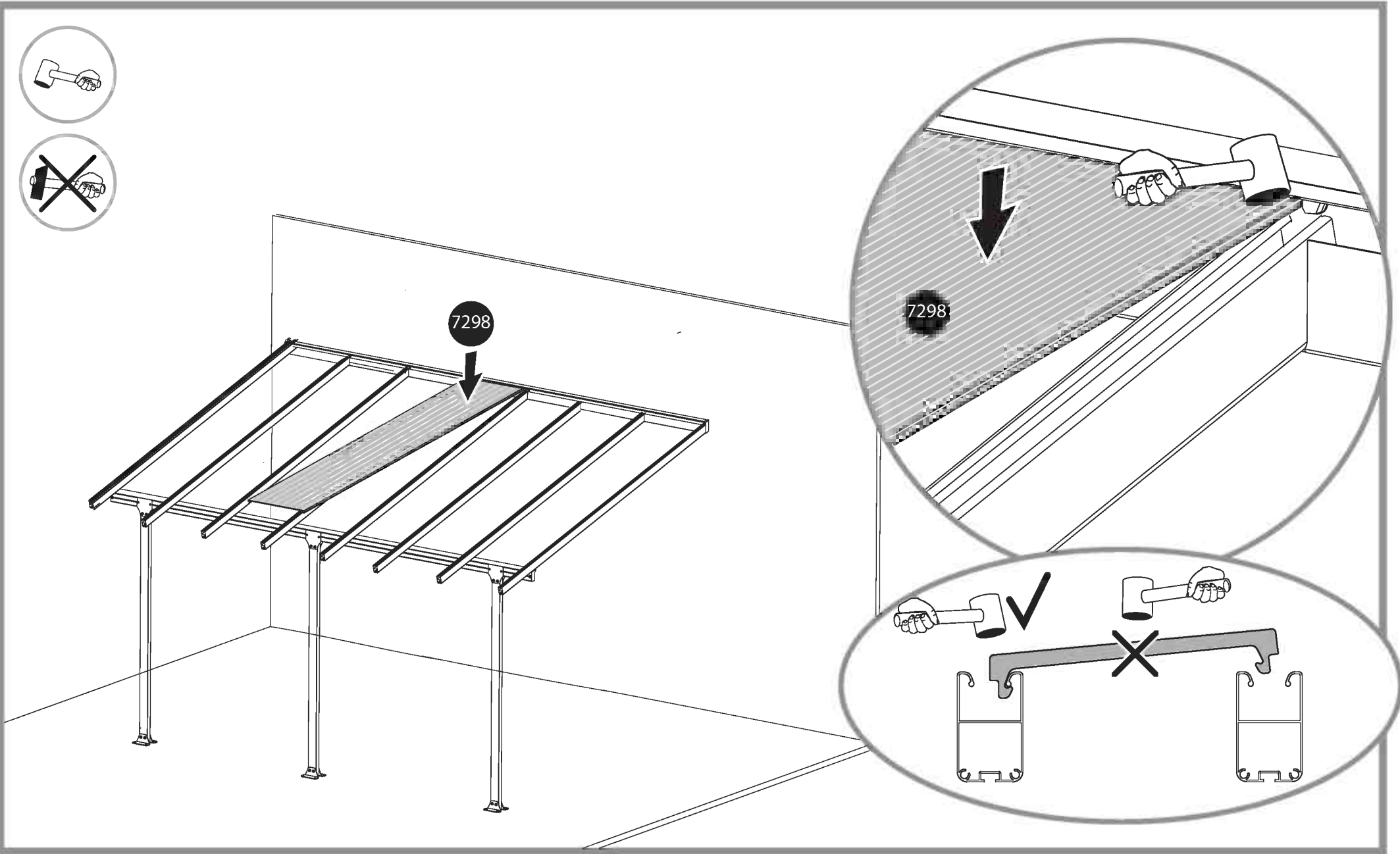
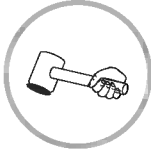

7298



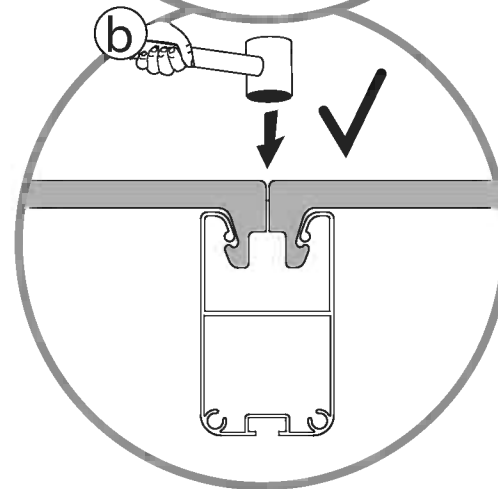
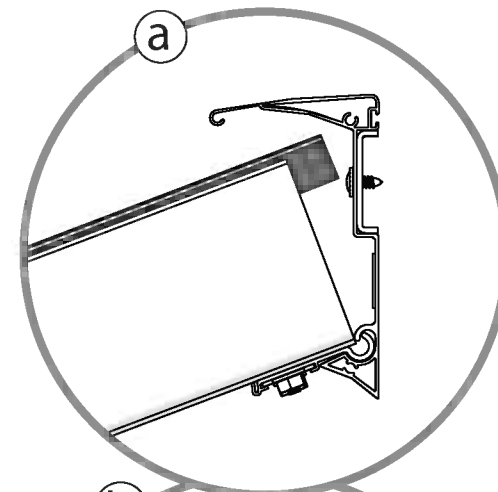
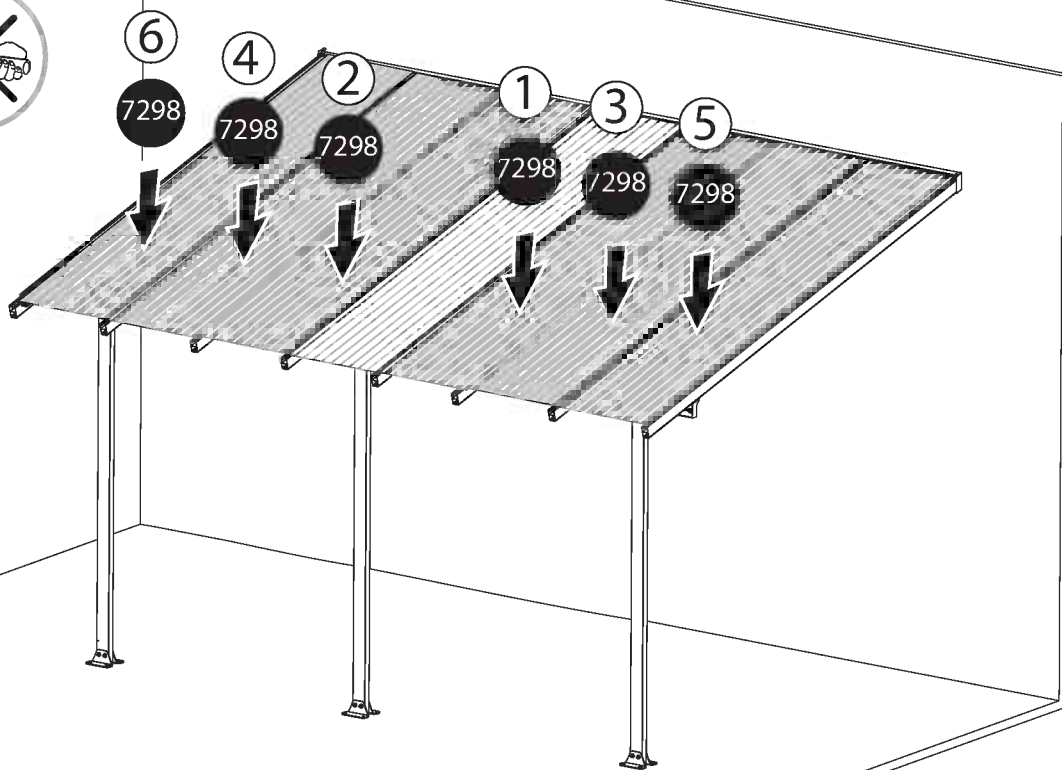
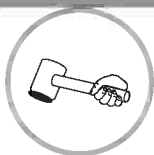

x6

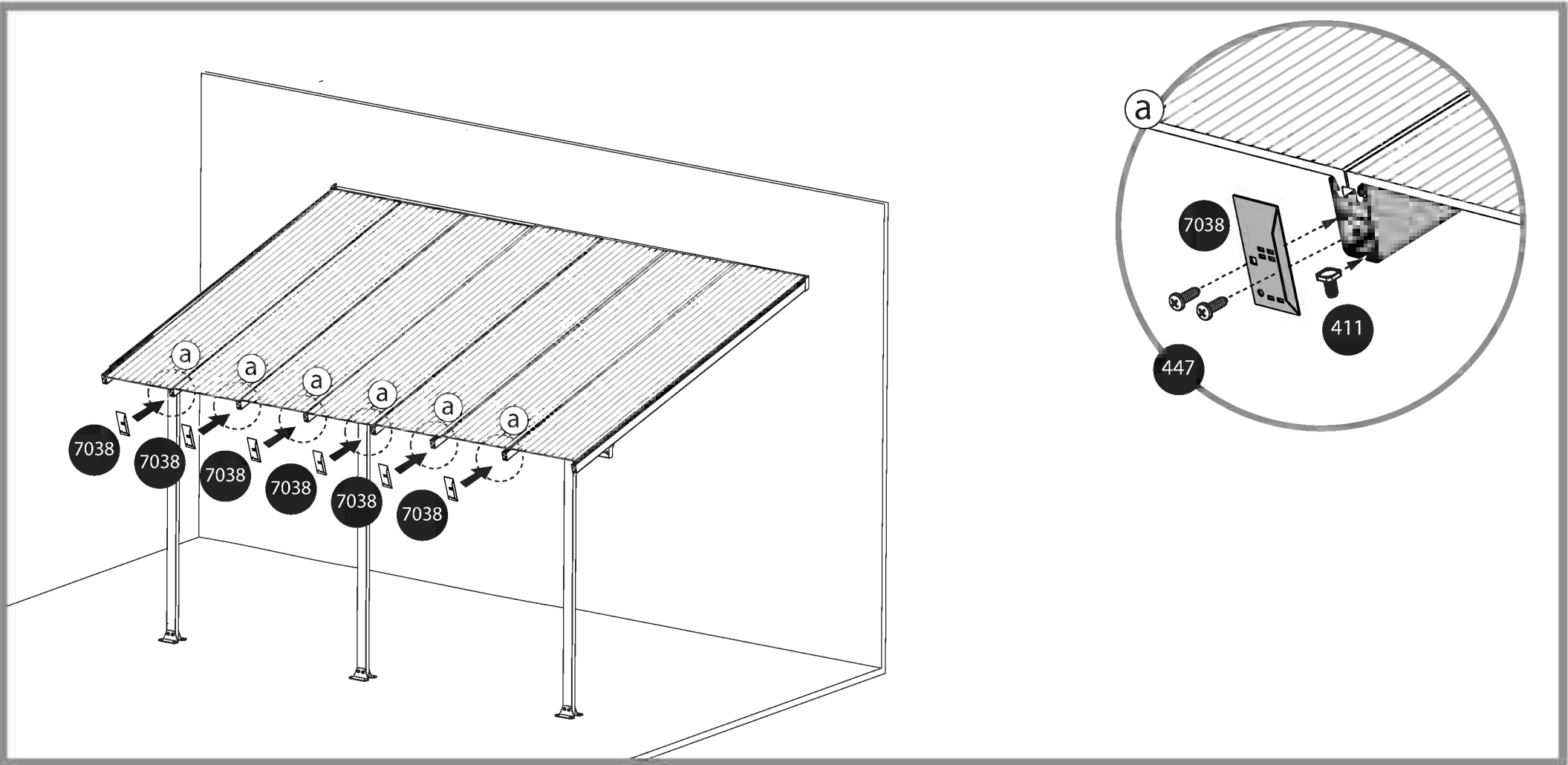
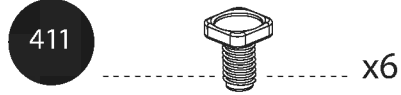
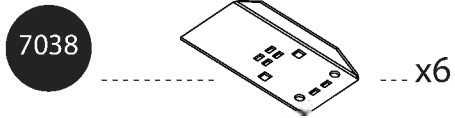

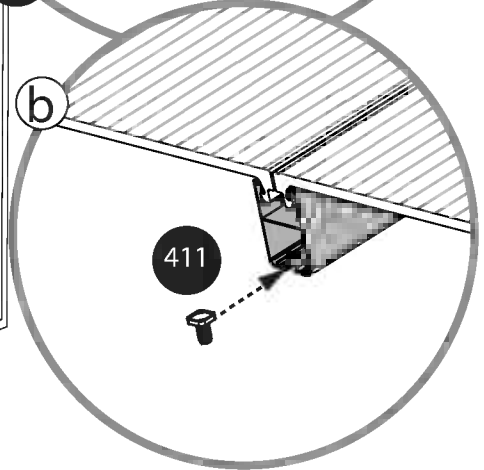
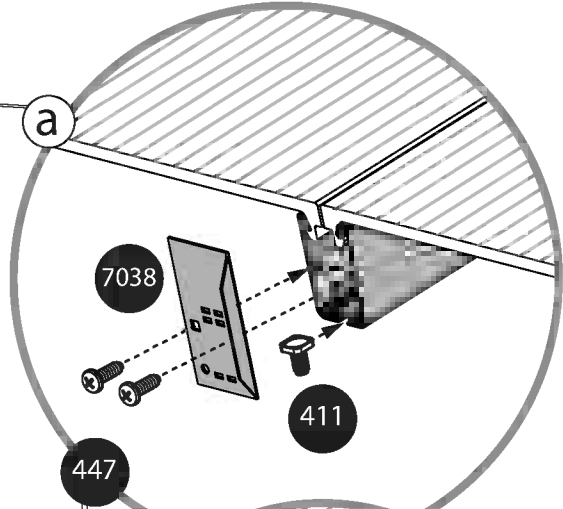
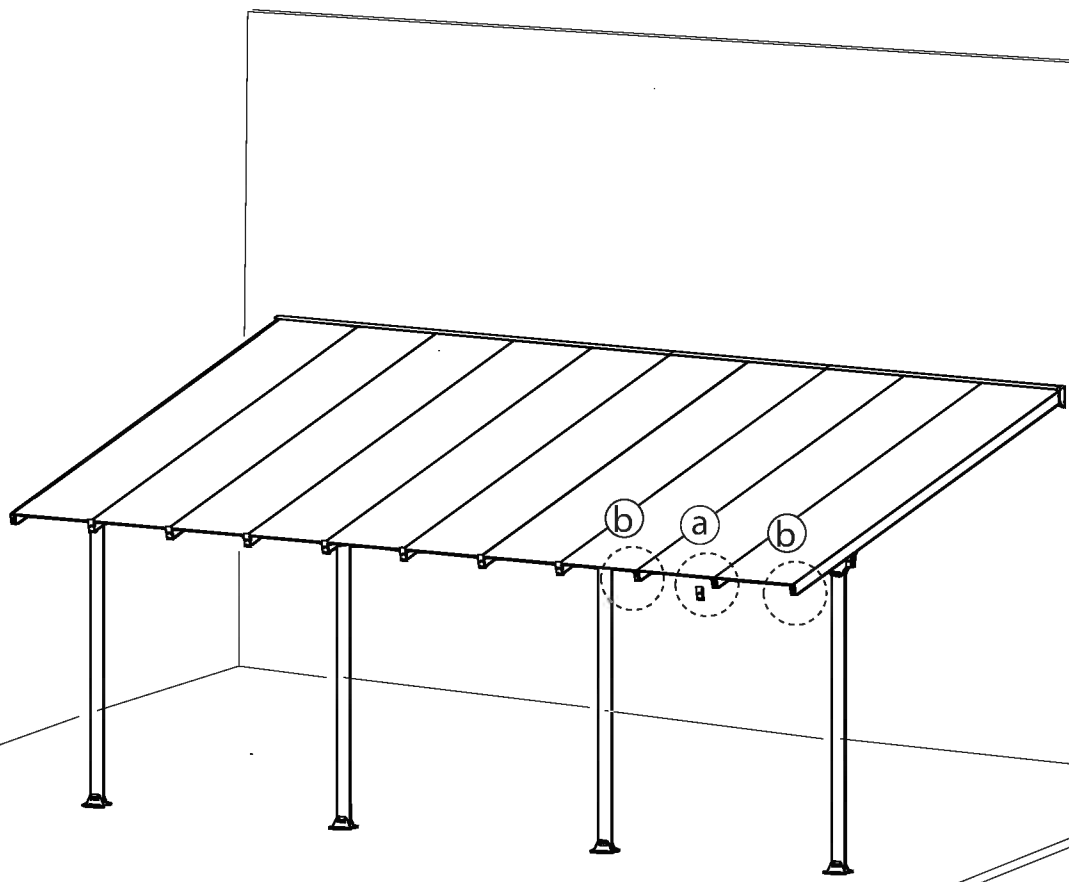
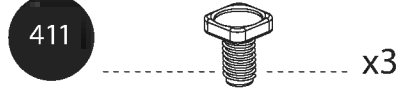
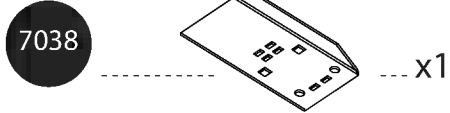

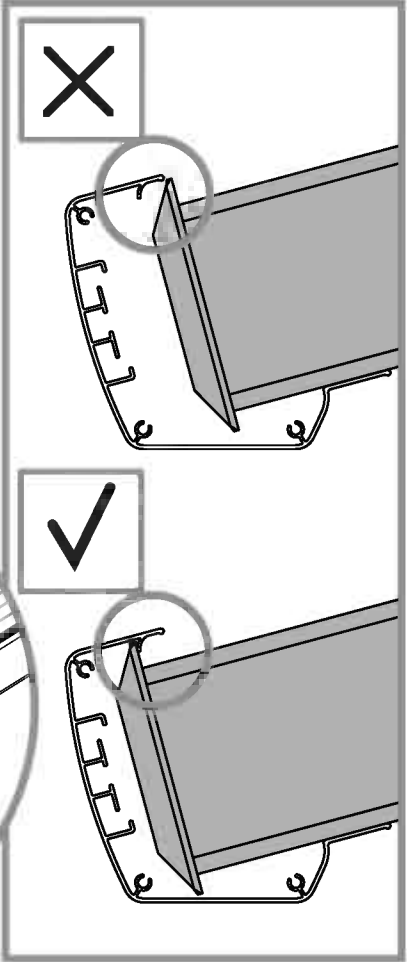
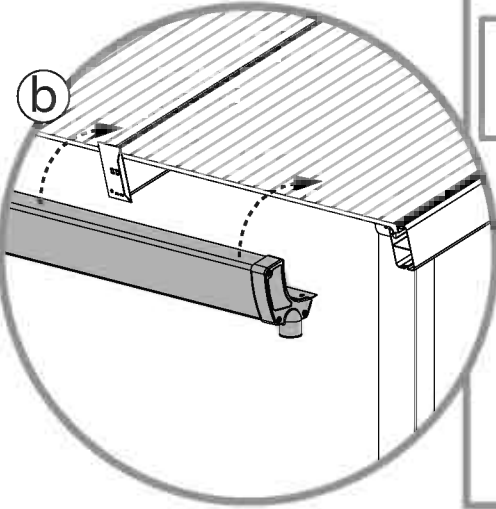
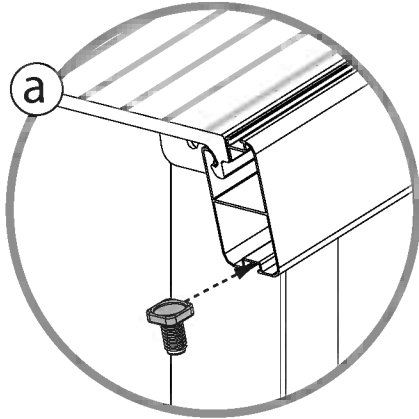
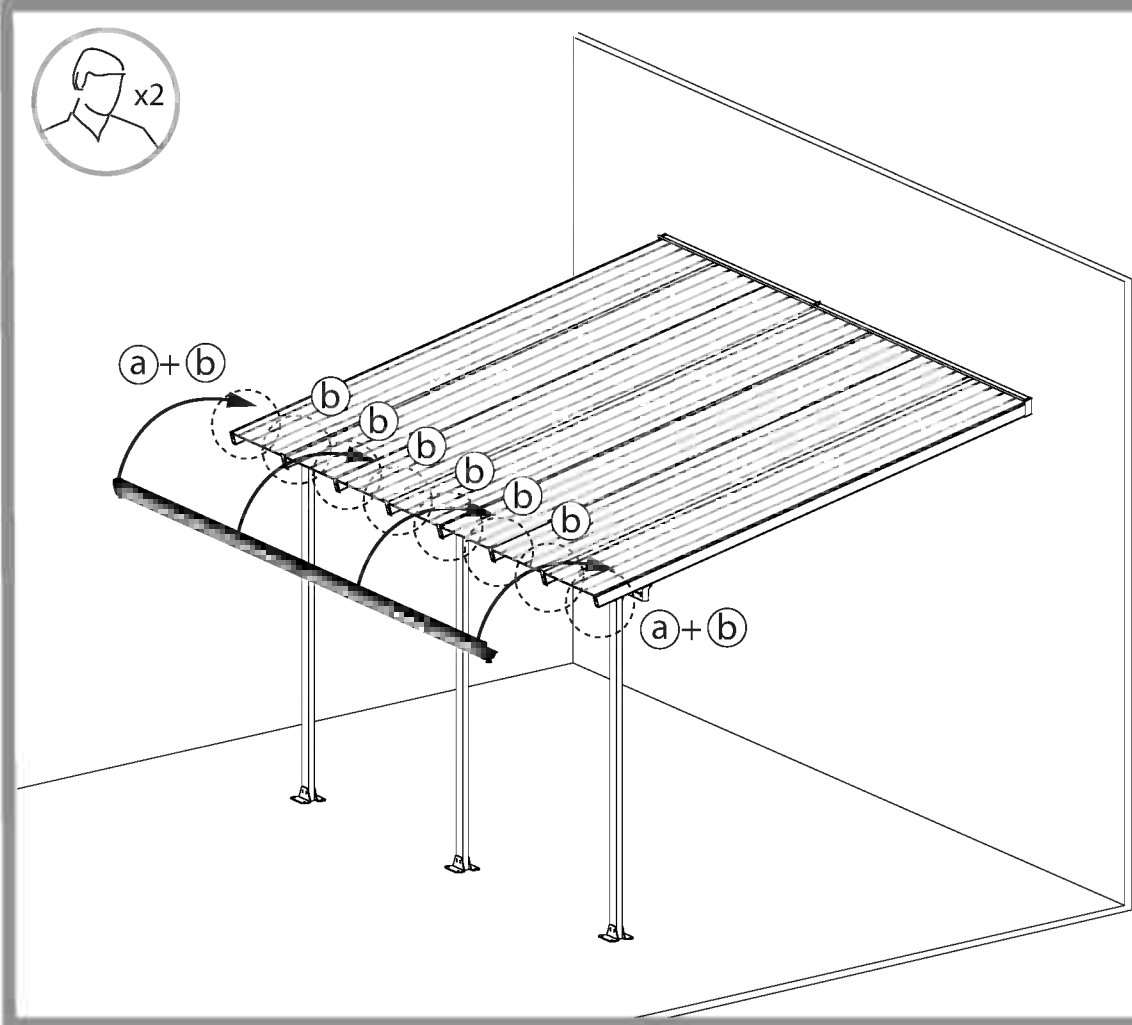
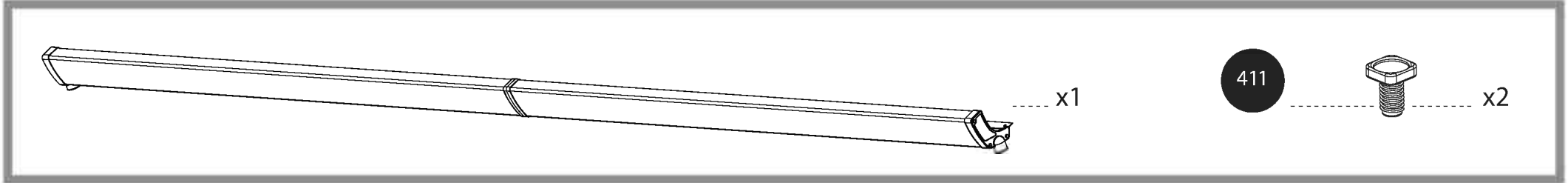





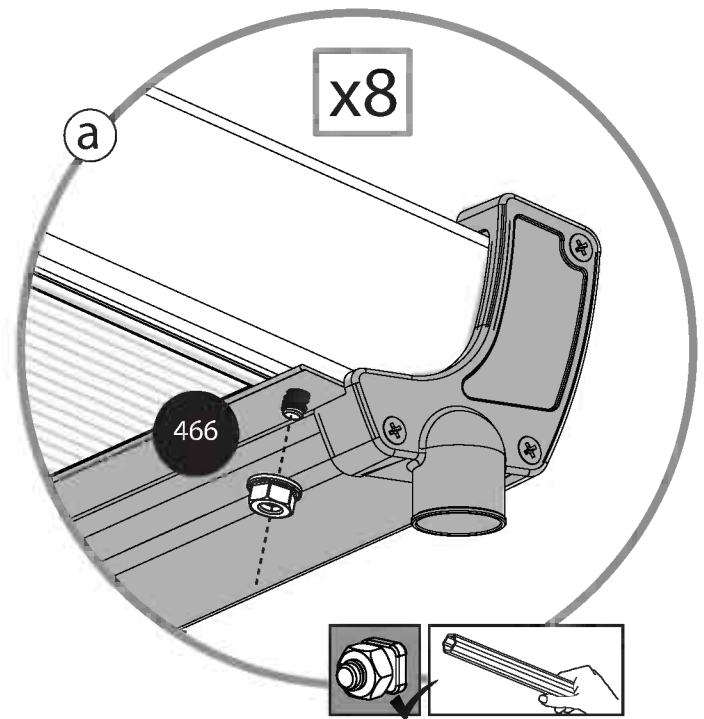
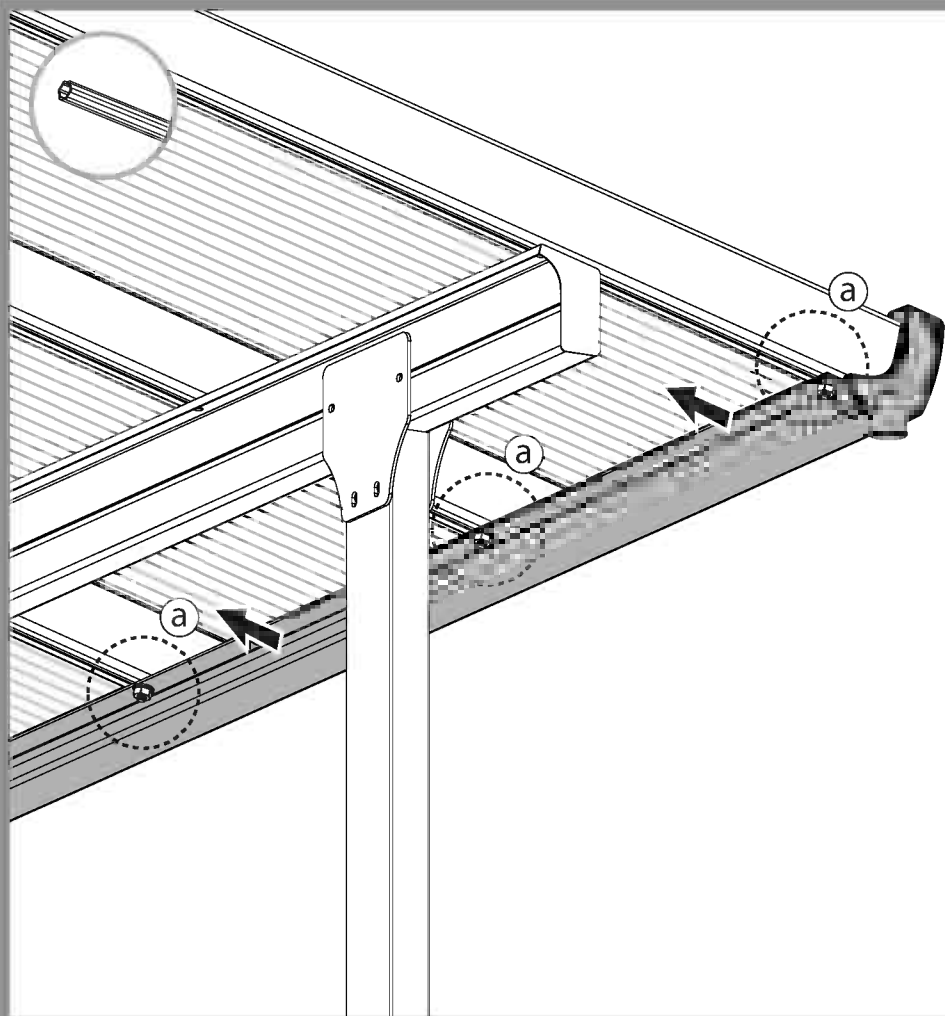

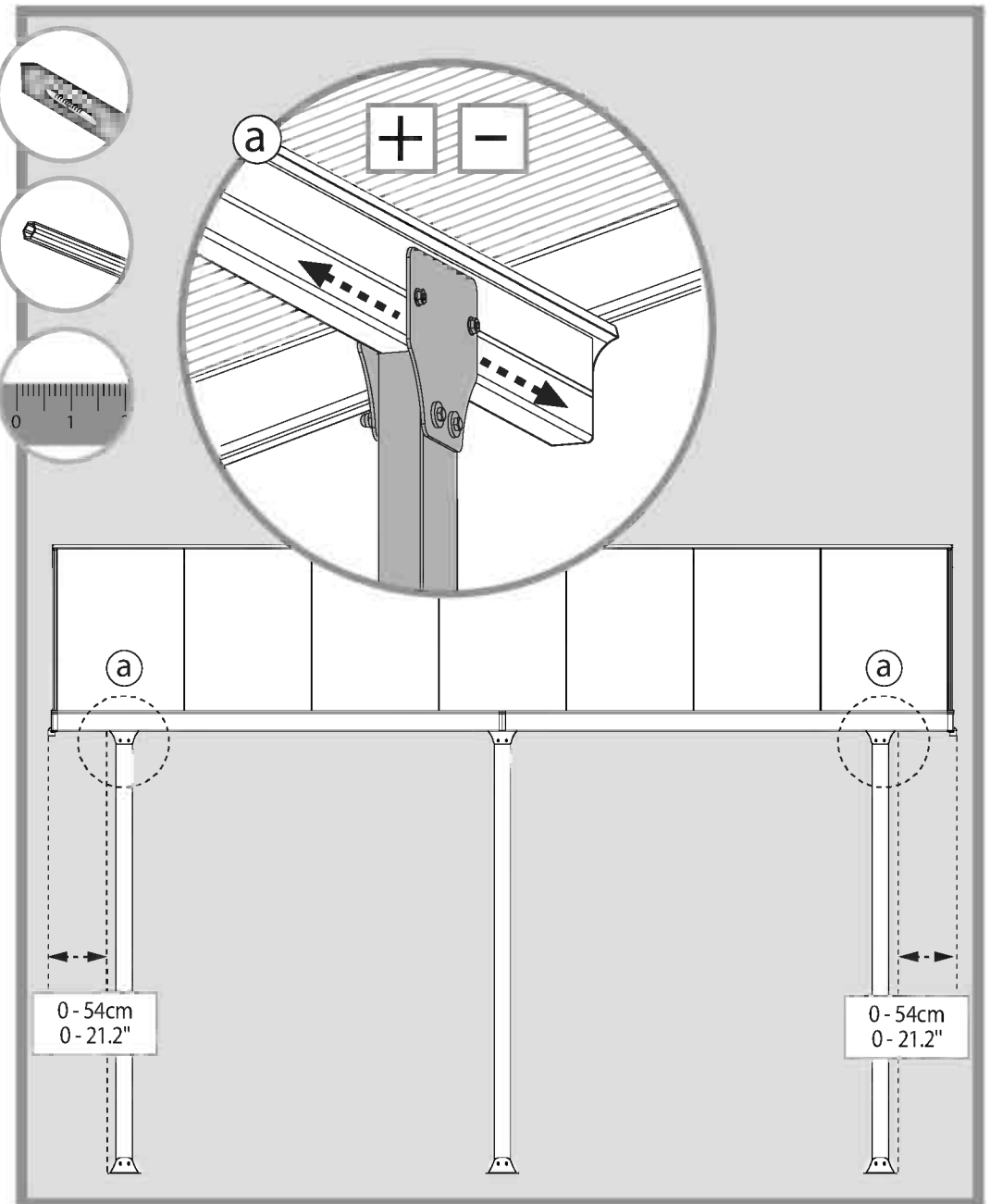
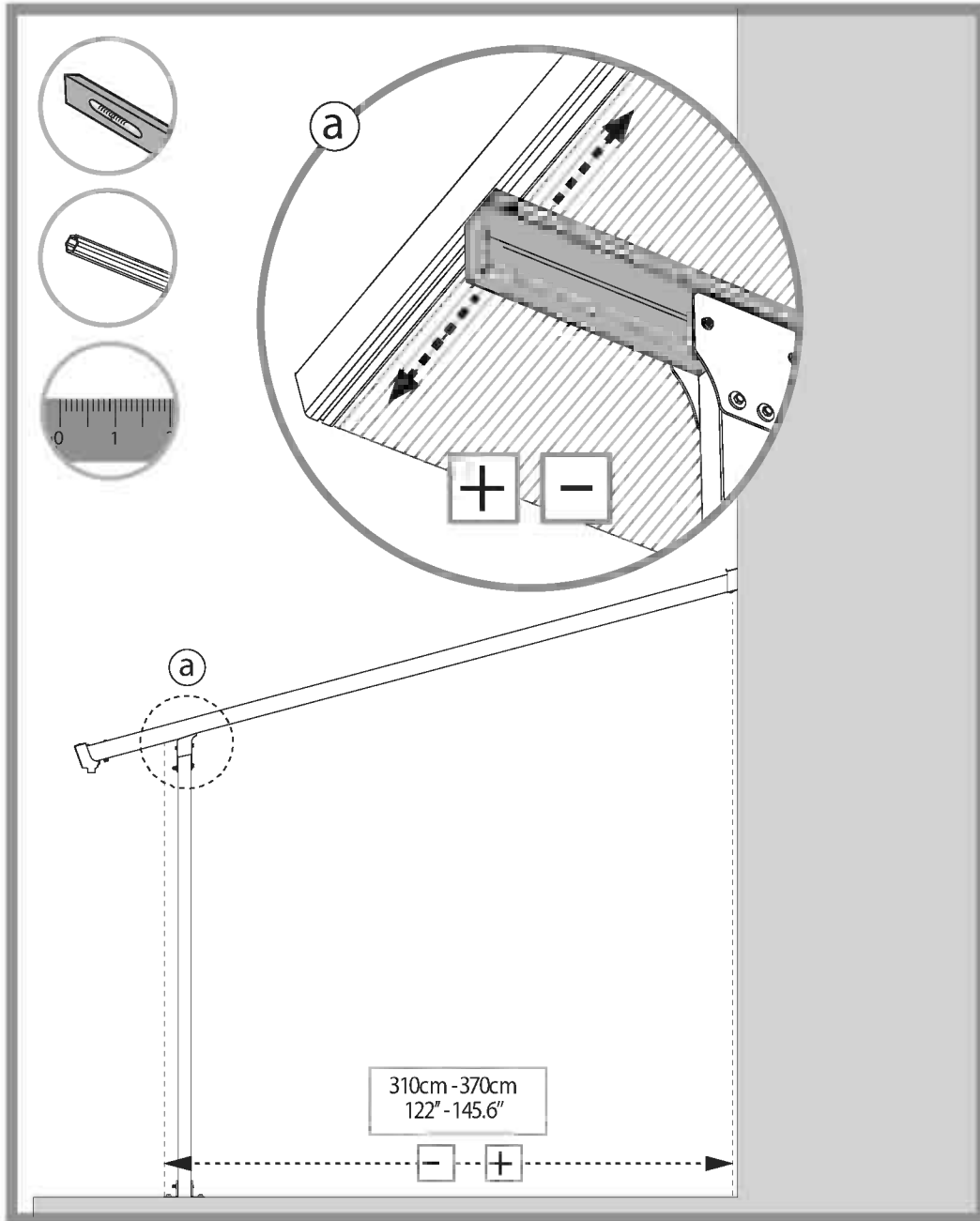
466  x8

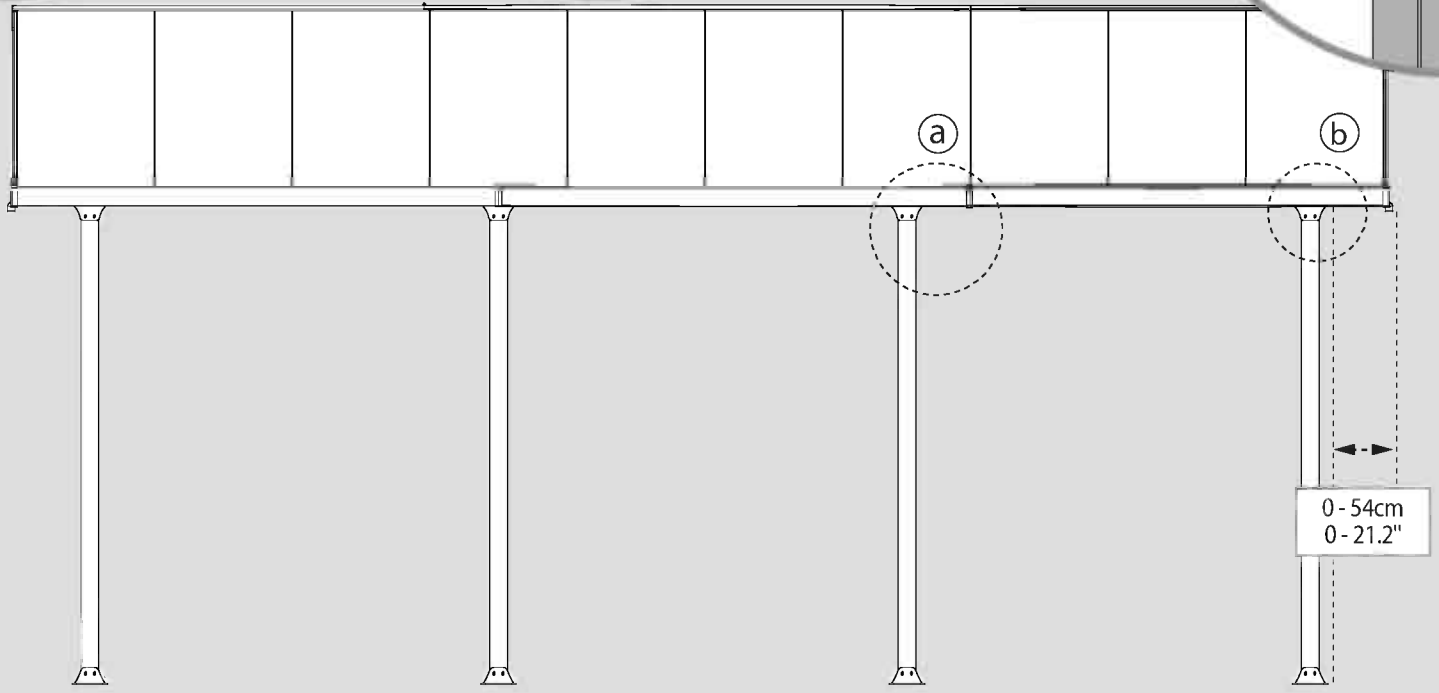
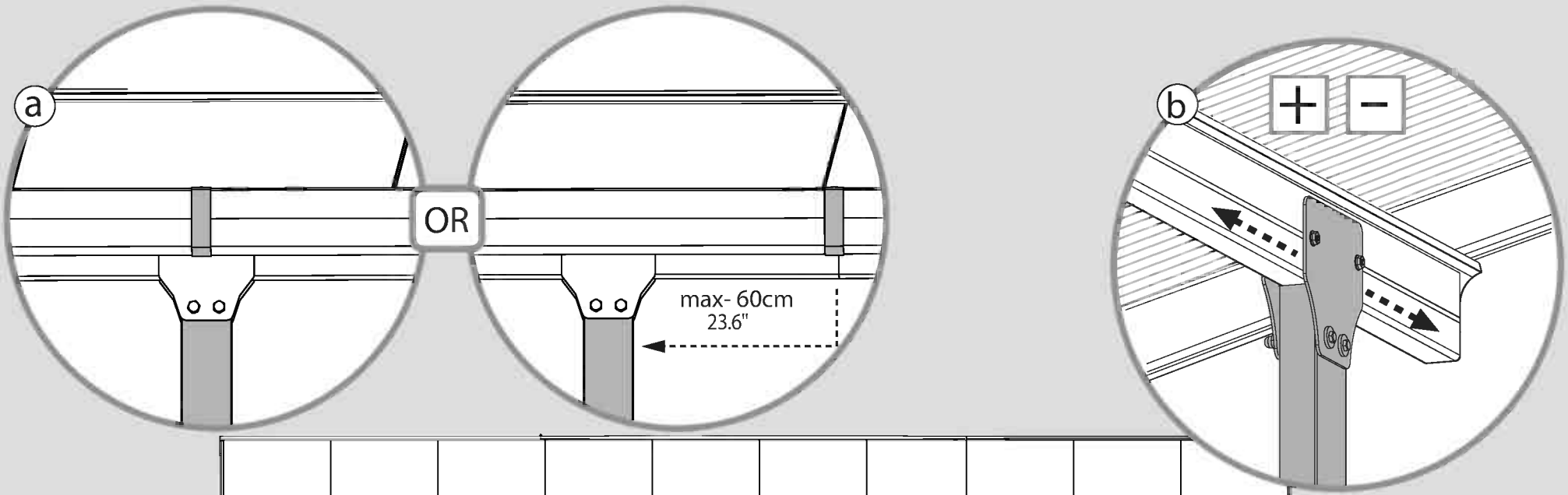



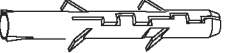

- 433  x12
- 4000  x12
- 5000  x12
- 4010  x12

