

ASSEMBLY INSTRUCTIONS

Platforms

Stationary, Rolling

Assembly Instructions Overview

Please read this brief overview before assembling your Hercke Series 7even system. What follows is an outline of the order in which your assembly process needs to occur.

1

A Phillips head N0. 2 screwdriver is the only tool required to assemble Hercke® Series 7even® products. Depending on your installation requirements, other tools that may be helpful include a level, power drill and drill bits.

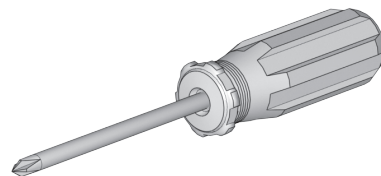

2

Assemble all platforms. Place platform in the desired location. Level each platform and make sure all platforms are level together.

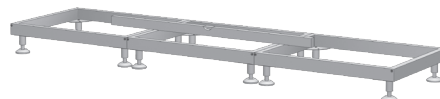

3

Pull platform out allowing yourself room to get behind the platform. Assemble cases. Stack cases and drawers on platforms in a single stack. Add Single E-Clips to the backside of cases and drawers. Slide the stack back into their final level position.

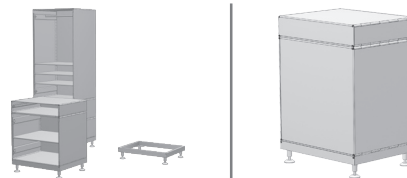

4

Assemble Overhead Storage Cases. Select overhead cabinet placement. Attach case using Wall Mount System or Channel Mount System.

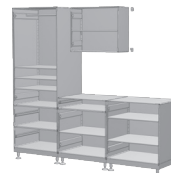

5

Fasten Single and Double E-Clips to adjoin cases and drawer modules.

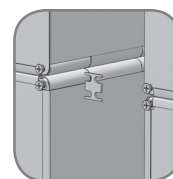

6

Snap door hinges to case hinge plates and adjust door positions.

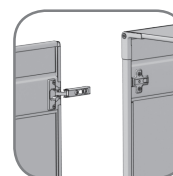
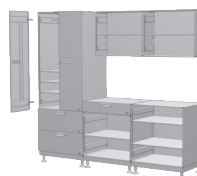

7

Attach work surface.

Chaos Defeated. Order Restored.

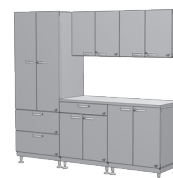

PARTS

ADJUSTABLE STATIONARY PLATFORM

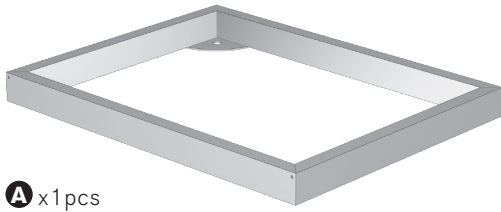

A x1 pcs
Platform Frame



B x4 pcs
Legs



C x4 pcs
Leg Screws
5/16"-18 x 3/4"
#2 Phillips Pan Head
Machine Screw



D x4 pcs
5/16" Split
Lock Washer



E x4 pcs
Rod Screw
1/4"-20 x 3/4"
#2 Phillips Pan Head
Machine Screw

1

A Assemble legs **B**

B Fasten legs **B** to platform frame **A** using parts **C** & **D** in the outer round hole as illustrated below.

C Insert screws **E** into the holes on the sides of the platform frame. (These will later be used with E-Clips and Double E-Clips to secure cabinets to the platform.)

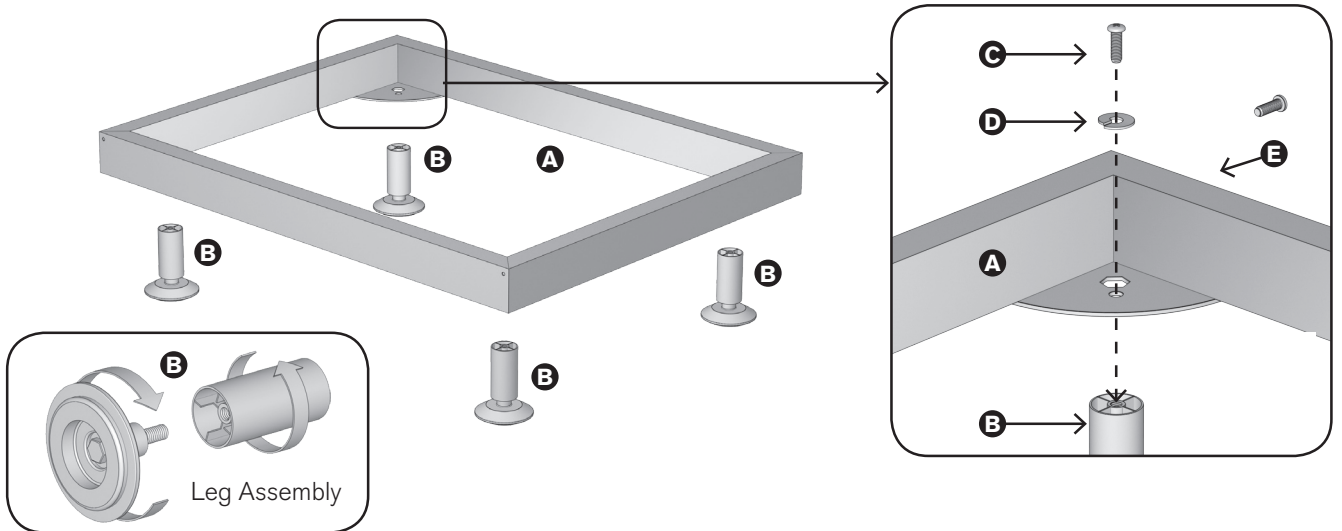

2

Rotate legs to adjust height and level platform.

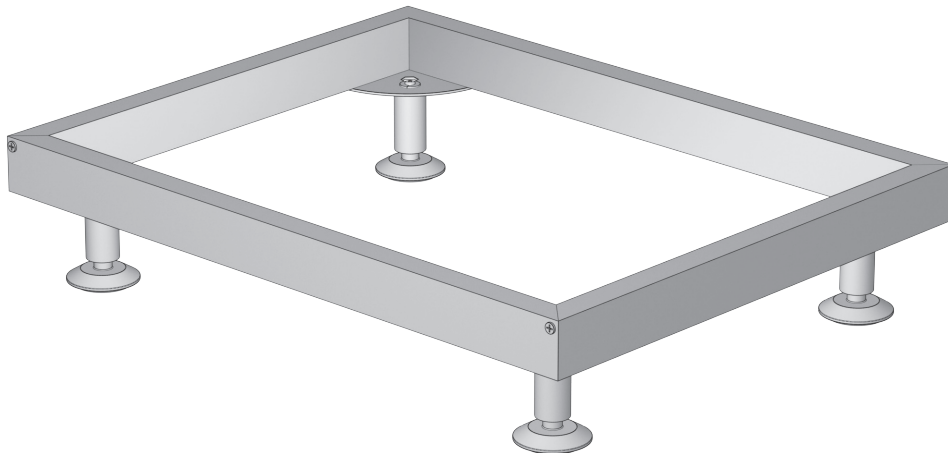

PARTS

LOCKING ROLLING PLATFORM

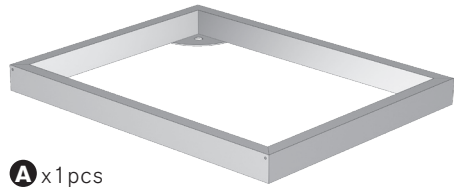

A x1 pcs
Platform Frame



D x4 pcs
Hex Nut
M12 x 1.75



C x2 pcs
Caster



E x4 pcs
Split Lock Washer
12mm



B x2 pcs
Locking Caster



F x1 pcs
Wrench



G x4 pcs
Rod Screw
1/4"-20 x 3/4"
#2 Phillips Pan Head
Machine Screw

1

- A** Fasten casters **B** & **C** to platform frame **A** using parts **D**, **E** & **F** as illustrated below. Make sure the caster posts are placed and seated in the hex hole. Place both rolling casters **C** on the back side of the platform and both of the locking casters **B** on the front side of the platform.
- B** Insert **G** screws into the holes on the sides of the platform frame. (These will later be used with E-Clips and Double E-Clips to secure cabinets to the platform.)

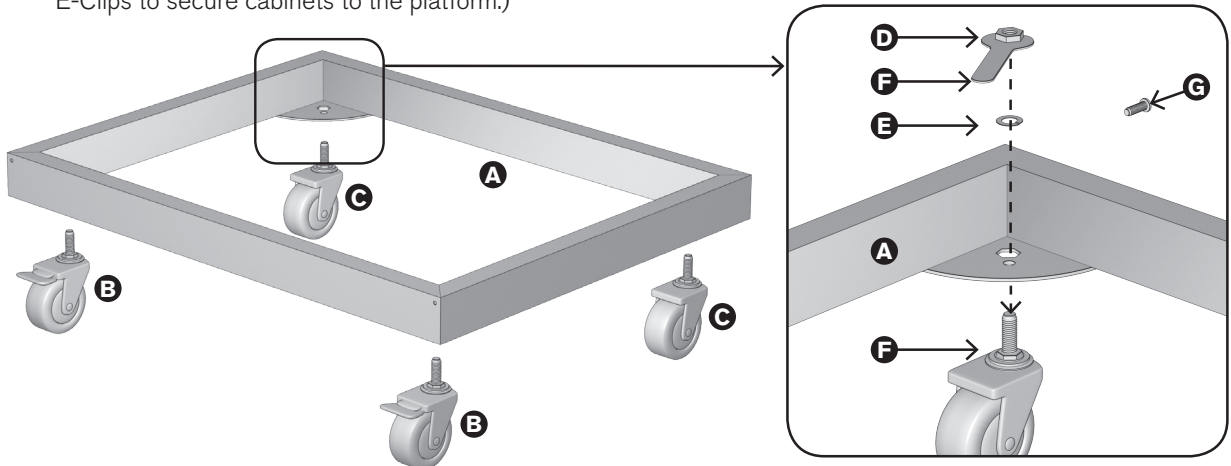

2

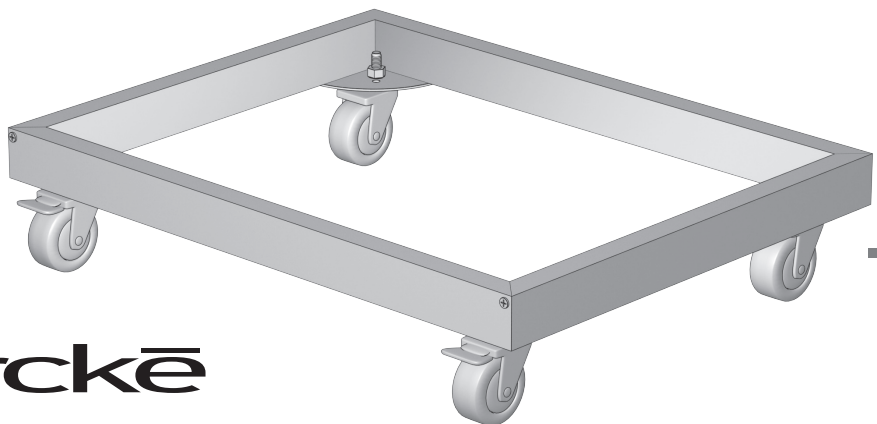

www.hercke.com | 866.767.3905 ext.16

Please visit www.hercke.com to download these instructions in your preferred language.